

The universal amplifier
for photodiodes
with built-in cooler
AM-07M

Operations manual

Contents

1. Application	3
2. Features	3
3. Service conditions	3
4. Appearance of the amplifier and its interface	3
5. Operating instruction	5
6. Technical characteristics	6
7. Block diagram	7

1. Application.

The amplifier AM-07M is designed for signal extraction and detection from IR-photodiodes manufactured by IBSG.

2. Features.

- The possibility of discrete changing of current amplification to raise the measurement accuracy.
- The presence of analog output for external device connection and LCD-display for signal level indication.
- The intrinsic function for background level compensation.

3. Service conditions.

Temperature tolerance	-15 °C..+15 °C
Relative air humidity (at temperature + 35°C)	less then 80 %
Atmospheric pressure	86..107 kPa

4. Appearance of the amplifier and its interface.

1. The jack for the PD connection.
2. The display for signal level indication.
3. The jack for the cable of AC/DC adapter.
4. The jack for synchronization cable.
5. The jack for external device connection (analog output).
6. The start/stop button of “ZERO” mode.
7. The button of discrete changing of current amplification.

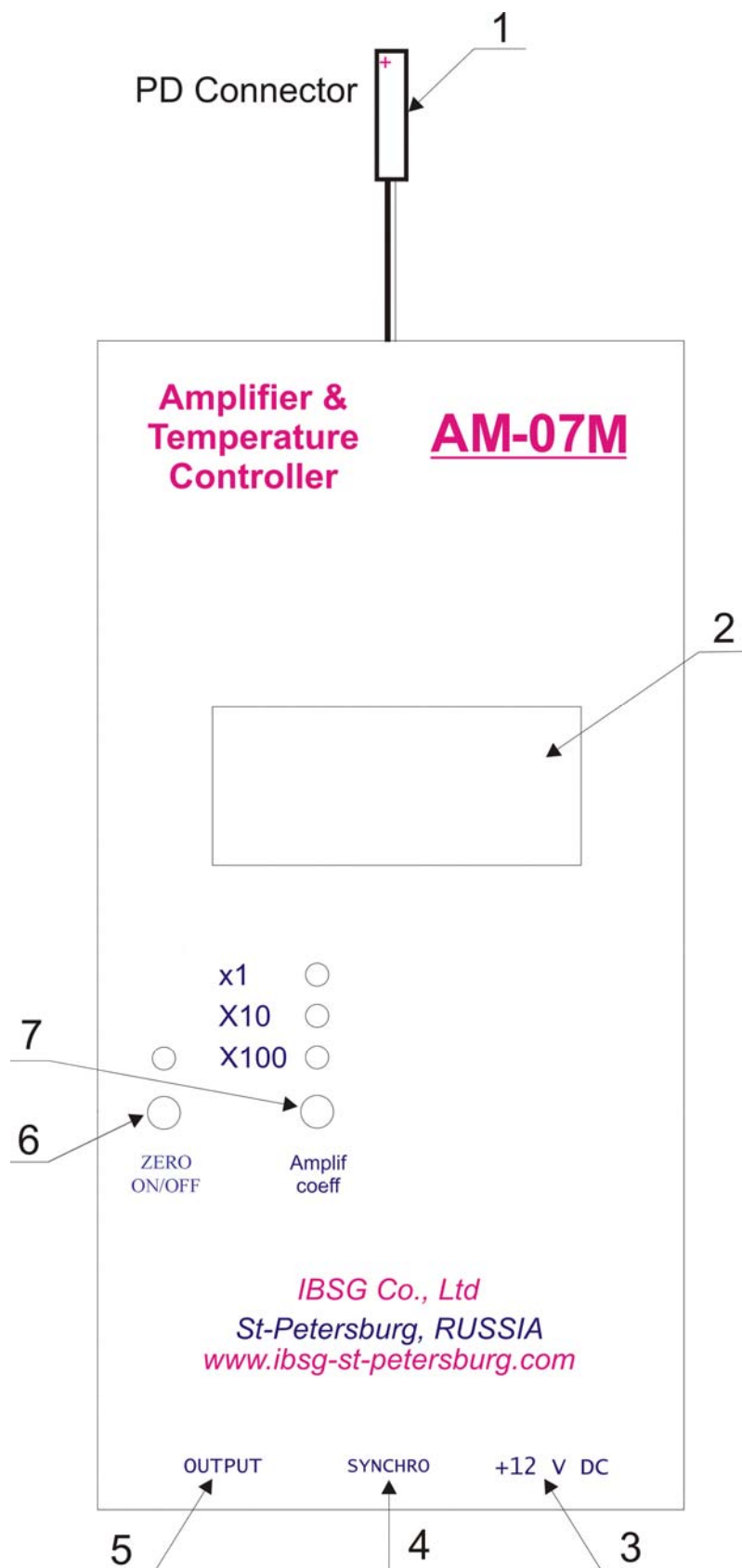

Fig.1. Appearance of the amplifier and its interface.

5. Operating instruction.

1. Please take a PD. Carefully combine its wires with pins of connector “PD” (1) tightly till fixation (fig.2).

Note! Marked with the red point pin of connector “PD” must be connected with the appropriate wire of the PD (fig.2). In the case of wrong junction the PD can be damaged.

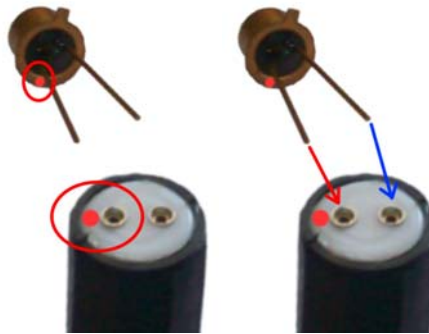

Fig.2. Observance of polarity during the connection between the PD and the PD connector (1).

2. With the help of the synchronization cable, connect the amplifier AM-07M(jack “SYNCRO” (4)) with the LED driver (for example with D-31 or DLT-37).

Figure 3.

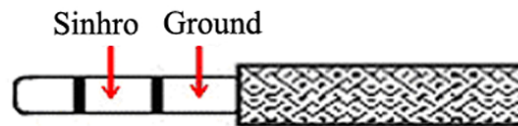

Fig.3. The polarity of jackplug of cable for synchronization.

Note! Without synchronization the amplifier readings can't be true.

3. If necessary with the help of a cable connect the “Output” (5) of AM-07M with recording instrument (for example oscilloscope or analog-to-binary converter).

Figure 4.

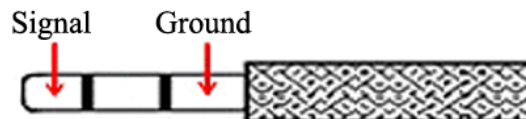

Fig.4. The polarity of jackplug of cable for external device connection.

4. Insert the jackplug of cable of AC/DC adapter into connector "+12V DC" (3). The AM-07M is operationally ready. Figure 5.

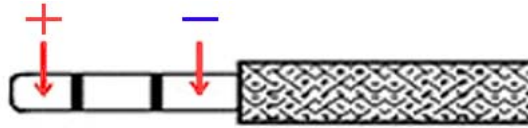

Fig.5. The polarity of jackplug of power cable.

5. Using the button “Amplif.coef” (7) select the requisite value of current amplification. The appropriate LED indicator will be turned on (“×1”, “×10” or “×100”). If the amplification of using PD will be too big you will see on the display the symbol “1___”. In that case, the coefficient of amplification should be decreased.

NOTE! The signal level is printed on the display in conventional units.

“ZERO” mode description.

The intrinsic function for background level compensation (“ZERO” mode) is used for amplification and measuring the difference between the current signal level and the signal taken for the zero level.

Using the start/stop button “ZERO ON/OFF” (6) this mode can be switched. The appropriate green LED indicator will be turned and the current signal is taken for the zero level in power up time.

6. Technical characteristics.

Input voltage	+12 V, stabilized
Voltage tolerance	-5..+5 %
Power consumption	Less then 3 W
Board dimensions	148×78×30 mm
Maximal amplification	$6,4 \times 10^6$ V/A
Maximal amplitude of output voltage	$ \pm 4 \text{ V} $
Output resistance	50 ohm
Transmission band with PD24	0,5 kHz – 20 kHz
Transmission band with PD25	0,5 kHz – 1 MHz

6. Block diagram

The block diagram of AM-07M is presented in fig.6. The amplifier functionally consists of the photodetector with PD and amplification-transformation circuit including preamplifier A1, bandpass amplifier BA, variable gain amplifier A2, synchronous demodulator SD, analog-to-digital converter ADC and liquid crystal display LCD. The amplifier feeding is implemented with the DC / DC circuit, which is a pulse voltage converter from + 12 V in + 5 V, -5 V. The input voltage of DC / DC converter supplies from +12 VDC jack.

Signal from the output of the photodetector comes to the preamplifier A1. It is enclosed in a metal shield for noise minimization. From the output of the preamplifier A1 the signal comes to the bandpass amplifier BA, which gain the signal in the band from 500 Hz to 50 kHz, and after that to the variable gain amplifier A2. The amplification can be changed by the button "Amplif. Coeff". The value of amplification is indicated by light-emitting diodes "1", "10" and "100".

From the output of the variable gain amplifier A2 the signal comes to the jack OUTPUT and for rectification to the synchronous demodulator SD, which receive clock pulses from the jack SYNCHRO. From the output of the synchronous demodulator SD (The output voltage is proportional to the signal amplitude) feed to the analog-digital converter ADC and then to the liquid-crystal indicator LCD DISPLAY.

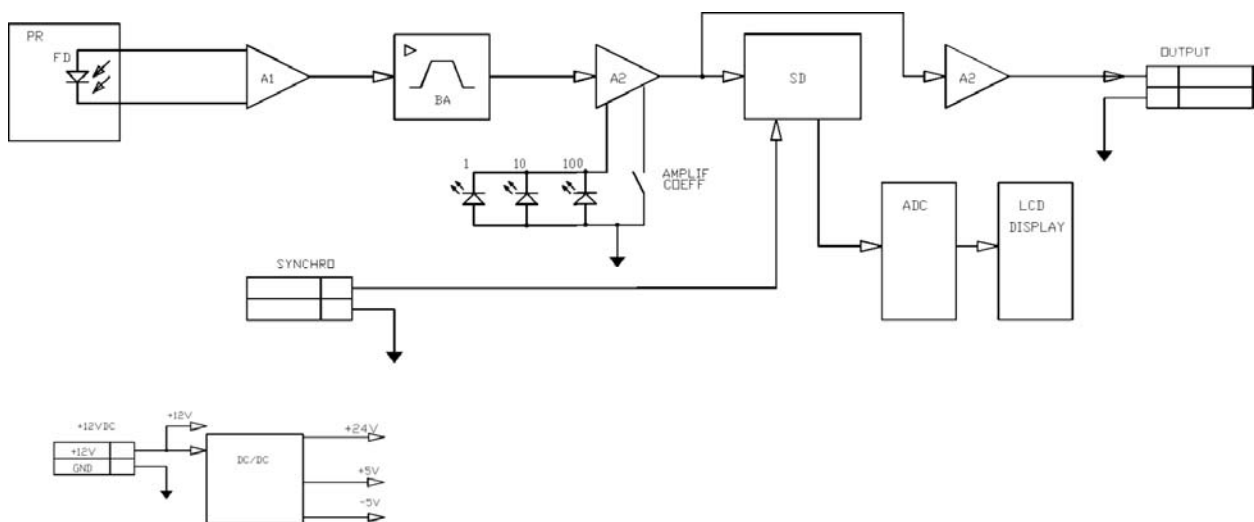

Fig.6. The Block diagram of AM-07M.