

Mini SpectralEye

Light curtains are frequently used for safety means in automation. The sensor introduced here provides object recognition and an additional material identification. It is possible therefore to let certain products pass the light curtain, while others are rejected. It can either be installed as a free-standing device or combined with a conveying system. The device consists of a 2D VNIR spectrometer system for analysis, control and evaluation electronics (DSP and microcontroller) and can be completed with a LED illumination.

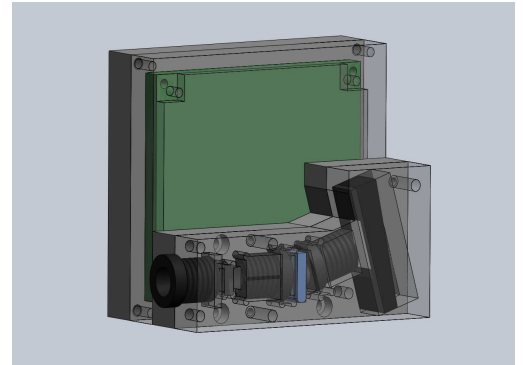

Features:

- **Easy installation and start-up**
- **No moving components, thus insensitive to shocks and vibrations**
- **Durable by use of LED illumination**
- **Identifies diverse plastics**
- **Identifies diverse organic chemical compounds**
- **Short testing time → fast evaluation**
- **Signal output via parameterisable outputs**
- **Low acquisition costs**

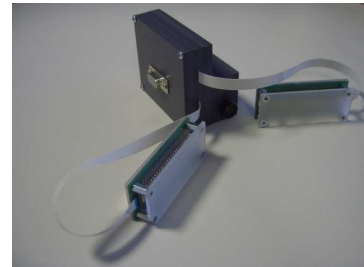
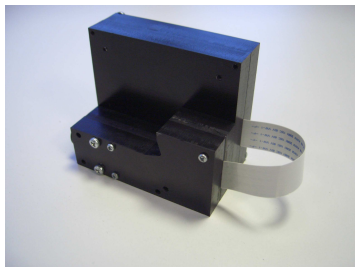

The sensor employs „Spectral Imaging“- 2D spectroscopy
Intensity and wavelength dependent characteristics of light are analysed.

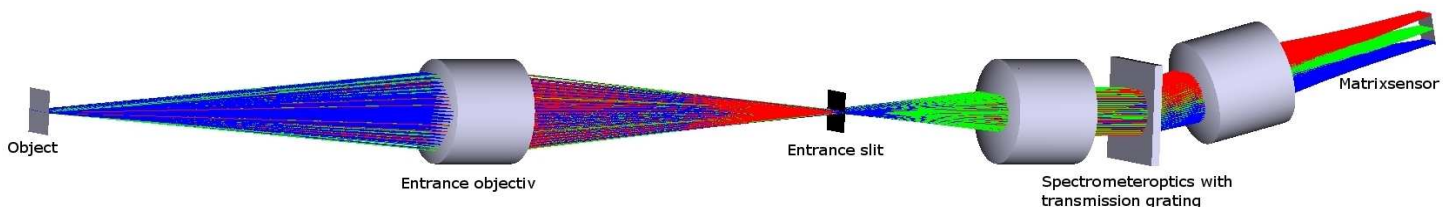

This technology enables identification of objects and materials at the same time. The figures down below show evaluations from diverse plastics.

Specifications

Mini SpectralEye	
Optical and spectral characteristics	
Sensor	1.3 MPix CMOS camera sensor
Spectral range	400-1000 nm, other configurations on request
Entrance objective	f = 16 mm (M12 x 0,5 mounting thread), other focal lengths on request
Illumination	LED illumination unit (wavelengths: 750 ... 970nm) other wavelengths on request
Mechanical characteristics	
Dimensions sensor unit	80 x 55 x 70(LxWxH in mm)
Dimensions illumination	74 x 31 x 11 (LxWxH in mm)
Material	ABS, black
Weight	350g
Electrical characteristics	
Outputs	Pin 1: material 1 detected, pin 2:: material 2 detected, pin 3: object in light path (can be parameterised differently)
Inputs	2 inputs optional
Specifications outputs	Optocoupler TTL 5V
Processor	Analogue devices DSP
Power supply	24 V DC
Power consumption	Max. 20W (2A)
Operational conditions	
Temperature (operating)	-10 ... +40 °C, non-condensing
Temperature (shipping)	-20 ... +65 °C, non-condensing
Humidity	20%-85% non-condensing
IP code	IP54
Warranty	2 years

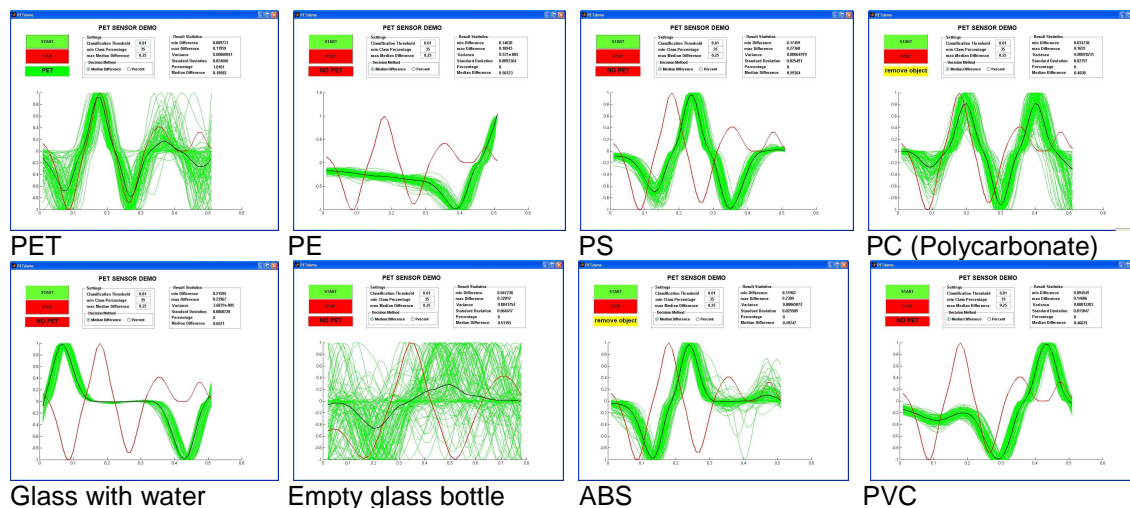

This product was subsidised by means of the Bundesministerium für Wirtschaft und Technologie.

