

DEXTER RESEARCH CENTER, INC.

Emissivity Correction for a Radiometer

The radiant power received by a radiometer is not only a function of the measured target temperature, but also the optical properties of its surface. These properties include absorptance a , reflectance ρ , and transmittance τ . For a Lambertian type surface they are related by Kirchoff's law

$$a + \rho + \tau = 1 \quad (1)$$

For most surfaces it can be assumed that $\varepsilon = a$ where ε is the emissive power of the specimen and by definition emissivity (ε) is the ratio of energy emitted from the target and that of a blackbody at the same temperature as the target.

The purpose of Fig. 1 is to illustrate the radiative balance between a target, a radiometer, and the environmental ambient background.

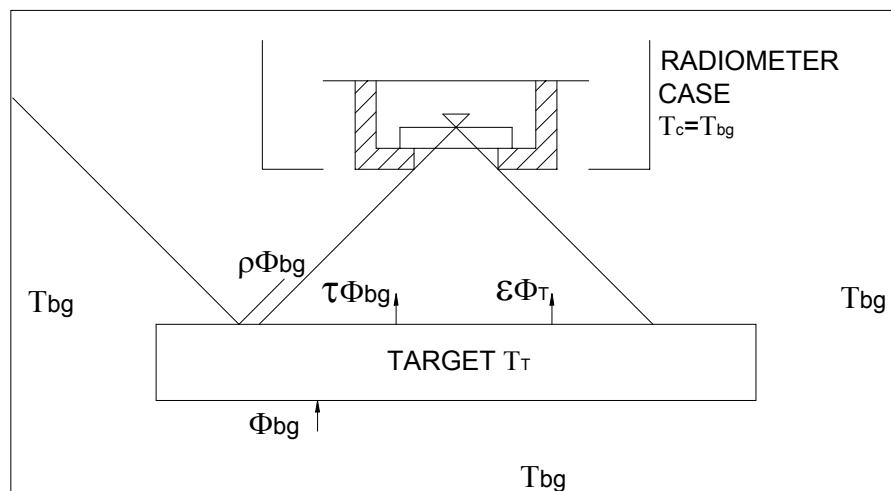

Fig. 1. Radiometer Radiative Inputs.

The total radiant power Φ_t incident on the active junctions of the thermopile detector is

$$\Phi_{TOT} = \varepsilon\Phi_T + \rho\Phi_{bg} + \tau\Phi_{bg} \quad (2)$$

with the aid of Kirchoff's law this equation may be written as

$$\Phi_{TOT} = \varepsilon\Phi_T + (1-\varepsilon)\Phi_{bg} \quad (3)$$

The energy radiated by the thermopile's active junctions is Φ_c and equals Φ_w when the radiometer case is the same temperature as the ambient background (bg). Now the energy balance for the thermopile's active junction is

$$\Phi_d = \Phi_{TOT} - \Phi_c = \epsilon\Phi_T + (1-\epsilon)\Phi_{bg} - \Phi_c \quad (4)$$

For the special conditions of the radiometer case and walls being isothermal

$$\Phi_d = \epsilon\Phi_T + \epsilon\Phi_{bg} \quad (5)$$

The voltage V_d generated by the thermopile is

$$V_d = \mathcal{R}\Phi_d = \epsilon\mathcal{R}(\Phi_T - \Phi_{bg}) \quad (6)$$

where \mathcal{R} is the thermopile's coefficient of responsivity in volts/watt.

Because emissivity enters into the calculation as a multiplication term, we may use a linear amplifier with gain of $1/\epsilon$ to cancel its effect. An emissivity correction circuit is illustrated in Fig. 2.

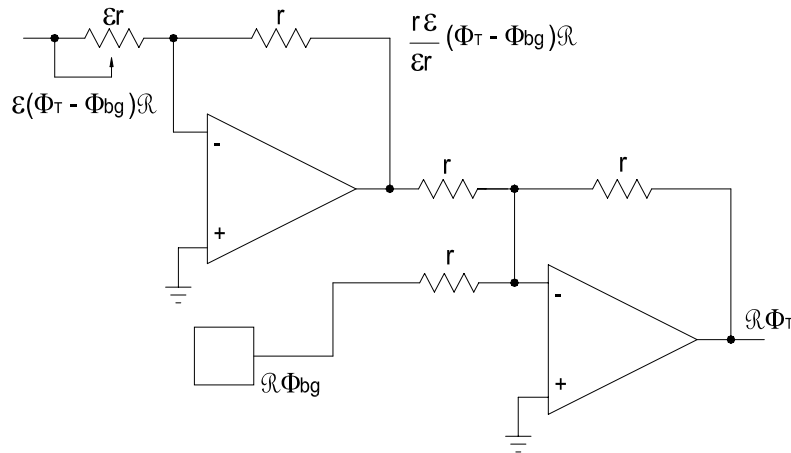

Fig. 2 Emissivity Correction Circuit

This computation scheme solves directly for $\mathcal{R}\Phi_T$, which is proportional to target temperature. Additionally, the correction is linear, and therefore, a linear variable resistor with a turns counting dial may be calibrated directly in emissivity.

This application brief has shown that when a temperature radiometer is used in an isothermal environment a simple computation circuit using linear amplifiers may be constructed to correct for target emissivity.