

Variable Gain 100 MHz Wideband Voltage Amplifier

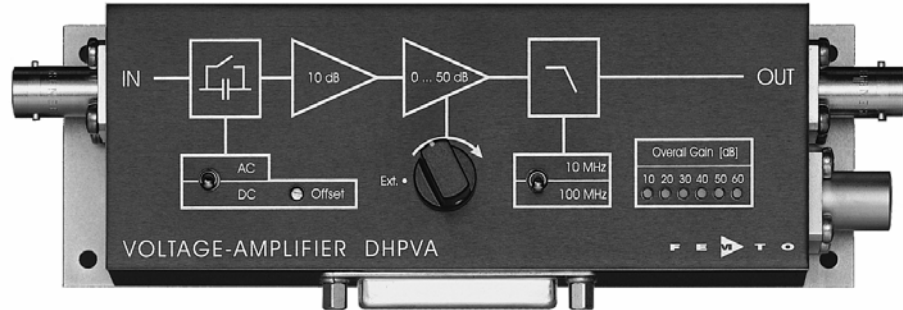

Features

- **Variable Gain 10 to 60 dB, Switchable in 10 dB Steps**
- **Bandwidth DC ... 100 MHz, Switchable to 10 MHz**
- **Built-In Temperature Compensation for Low Drift of 0.6 μ V/K**
- **2.5 nV/ \sqrt Hz Input Noise**
- **Switchable AC/DC-Coupling**
- **Bandwidth, Frequency- and Pulse Response Independent of Gain Setting**
- **Local and Remote Control**
- **DC Monitor Output**

Applications

- **Oscilloscope and Transient-Recorder Preamplifier**
- **Photomultiplier and Microchannel-Plate Amplifier**
- **Signal-Booster for Optical Receivers and Current Amplifiers**
- **Time-Resolved Pulse and Transient Measurements**
- **Automated Measurement Systems**
- **Integration in Compact Systems**

Block Diagram

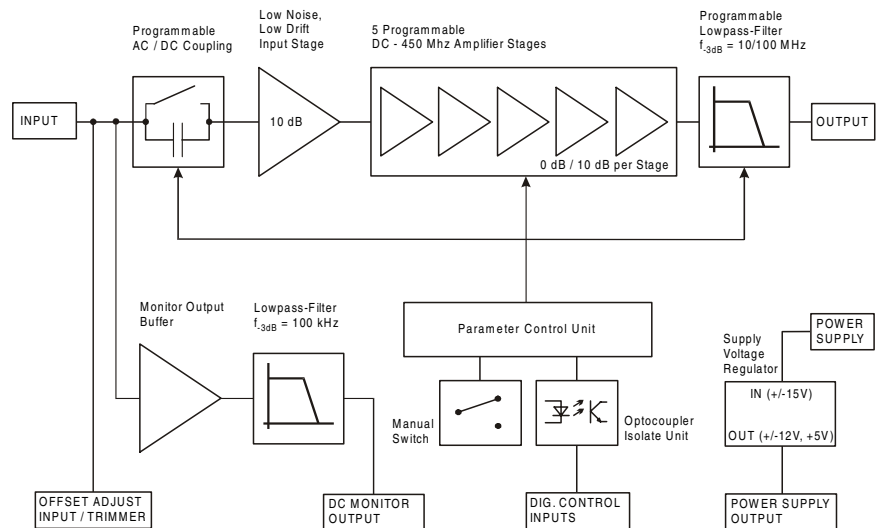

BS01-0540-17

Variable Gain 100 MHz Wideband Voltage Amplifier

Specifications	<i>Test Conditions</i>	<i>V_s = ± 15 V, T_a = 25°C, System Impedance = 50 Ω</i>
Gain	Gain Values Gain Accuracy	10, 20, 30, 40, 50, 60 dB ± 0.15 dB (between settings) ± 0.3 dB (overall)
Frequency Response	Lower Cut-Off Frequency Upper Cut-Off Frequency Upper Cut-Off Frequency Roll-off	DC / 10 Hz 100 MHz, switchable to 10 MHz (approx. Bessel filter characteristic for clear pulse response) 25 dB/Oct.
Time Response	Rise / Fall Time (10% - 90%)	3.5 ns (@ 100 MHz) 35 ns (@ 10 MHz)
Input	Input Impedance Input Voltage Drift Equivalent Input Voltage Noise Equivalent Input Current Noise 1/f-Noise Corner Input BIAS Current Input Offset Voltage	50 Ω // 5 pF 0.6 μV/K 2.5 nV/√Hz (@ 30 – 60 dB gain) 3.0 pA/√Hz 15 kHz < 200 nA - 10 mV ... + 10 mV, adjustable by offset-trimmer and external control voltage
Output	Output Impedance Output Voltage Range Output Power (max.) Output Current (max.) THD	50 Ω (terminate with 50 Ω load for best performance) 2 V _{pp} (for linear amplification) + 10 dBm 70 mA < 0.5 % (@ 10 MHz, 1 V _{pp})
Monitor Output	Monitor Output Gain Monitor Output Voltage Range Monitor Output Current Monitor Output Bandwidth	1 ± 5 V ± 10 mA DC ... 100 kHz
Indicator LED	Function	gain setting
Digital Control	Control Input Voltage Range Control Input Current Gain Control Switching Time	Low: - 0.8 ... + 0.8 V High: + 1.8 ... + 12 V, TTL / CMOS compatible 0 mA @ 0V, 1.5 mA @ + 5 V, 4.5 mA @ + 12V 5 ms
Ext. Offset Control	Control Voltage Range Offset Control Input Impedance	± 10 V, corresponds to ± 10 mV input offset 200 kΩ
Power Supply	Supply Voltage Supply Current Stabilized Power Supply Output	± 15 V ± 120 mA typ. (depends on operating conditions, recommended power supply capability minimum 250 mA) ± 12 V / max. 100 mA, + 5V / max. 50 mA
Case	Weight Material	350 g (0.81 lbs) AlMg4.5Mn, nickel-plated
Temperature Range	Storage Temperature Operating Temperature	- 40 °C ... + 100 °C 0 °C ... + 60 °C

Variable Gain 100 MHz Wideband Voltage Amplifier

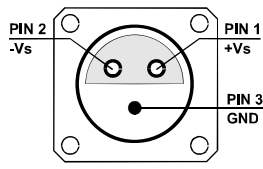
Absolute Maximum Ratings	<table style="width: 100%; border-collapse: collapse;"> <tr> <td style="padding: 2px;">Power Supply Voltage</td> <td style="padding: 2px; text-align: right;">$\pm 20\text{ V}$</td> </tr> <tr> <td style="padding: 2px;">Signal Input Voltage</td> <td style="padding: 2px; text-align: right;">$\pm 5\text{ V}$</td> </tr> <tr> <td style="padding: 2px;">Digital Control Input Voltage</td> <td style="padding: 2px; text-align: right;">$+ 16\text{ V} / - 5\text{ V}$</td> </tr> </table>	Power Supply Voltage	$\pm 20\text{ V}$	Signal Input Voltage	$\pm 5\text{ V}$	Digital Control Input Voltage	$+ 16\text{ V} / - 5\text{ V}$		
Power Supply Voltage	$\pm 20\text{ V}$								
Signal Input Voltage	$\pm 5\text{ V}$								
Digital Control Input Voltage	$+ 16\text{ V} / - 5\text{ V}$								
Connectors	<table style="width: 100%; border-collapse: collapse;"> <tr> <td style="padding: 2px;">Input</td> <td style="padding: 2px;">BNC</td> </tr> <tr> <td style="padding: 2px;">Output</td> <td style="padding: 2px;">BNC</td> </tr> <tr> <td style="padding: 2px;">Power Supply</td> <td style="padding: 2px;"> LEMO series 1S, 3-pin fixed socket Pin 1: + 15V Pin 2: - 15V Pin 3: GND </td> </tr> </table> <div style="text-align: center; margin: 10px 0;">  </div> <table style="width: 100%; border-collapse: collapse;"> <tr> <td style="padding: 2px;">Control Port</td> <td style="padding: 2px;"> Sub-D 25-pin, female, qual. class 2 Pin 1: +12V (stabilized power supply output) Pin 2: -12V (stabilized power supply output) Pin 3: AGND (analog ground) Pin 4: +5V (stabilized power supply output) Pin 5: monitor output Pin 6, 7: NC Pin 8: offset control voltage input Pin 9: DGND (ground f. digital control Pin 10 - 25) Pin 10: digital control input: gain, LSB Pin 11: digital control input: gain Pin 12: digital control input: gain, MSB Pin 13: digital control input: AC/DC Pin 14: digital control input: 100 MHz/10 MHz Pin 15 - 25: NC </td> </tr> </table>	Input	BNC	Output	BNC	Power Supply	LEMO series 1S, 3-pin fixed socket Pin 1: + 15V Pin 2: - 15V Pin 3: GND	Control Port	Sub-D 25-pin, female, qual. class 2 Pin 1: +12V (stabilized power supply output) Pin 2: -12V (stabilized power supply output) Pin 3: AGND (analog ground) Pin 4: +5V (stabilized power supply output) Pin 5: monitor output Pin 6, 7: NC Pin 8: offset control voltage input Pin 9: DGND (ground f. digital control Pin 10 - 25) Pin 10: digital control input: gain, LSB Pin 11: digital control input: gain Pin 12: digital control input: gain, MSB Pin 13: digital control input: AC/DC Pin 14: digital control input: 100 MHz/10 MHz Pin 15 - 25: NC
Input	BNC								
Output	BNC								
Power Supply	LEMO series 1S, 3-pin fixed socket Pin 1: + 15V Pin 2: - 15V Pin 3: GND								
Control Port	Sub-D 25-pin, female, qual. class 2 Pin 1: +12V (stabilized power supply output) Pin 2: -12V (stabilized power supply output) Pin 3: AGND (analog ground) Pin 4: +5V (stabilized power supply output) Pin 5: monitor output Pin 6, 7: NC Pin 8: offset control voltage input Pin 9: DGND (ground f. digital control Pin 10 - 25) Pin 10: digital control input: gain, LSB Pin 11: digital control input: gain Pin 12: digital control input: gain, MSB Pin 13: digital control input: AC/DC Pin 14: digital control input: 100 MHz/10 MHz Pin 15 - 25: NC								

Variable Gain 100 MHz Wideband Voltage Amplifier

Remote Control Operation	<p>General</p> <p>Remote control input bits are opto-isolated and connected by logical OR to local switch setting. For remote control a switch setting, set the corresponding local switch to "Ext.", "AC" or "10 MHz" and select the wanted setting via a bit-code at the corresponding digital inputs. Mixed operation, e.g. local gain setting and remote controlled bandwidth setting is also possible.</p>																																			
	<table style="width: 100%; border-collapse: collapse;"> <tr> <td style="width: 30%;">Gain Setting</td> <td style="width: 15%;">Gain</td> <td style="width: 15%;">Pin 10</td> <td style="width: 15%;">Pin 11</td> <td style="width: 15%;">Pin 12</td> </tr> <tr style="border-top: 1px solid black; border-bottom: 1px solid black;"> <td></td> <td>10 dB</td> <td>low</td> <td>low</td> <td>low</td> </tr> <tr> <td></td> <td>20 dB</td> <td>high</td> <td>low</td> <td>low</td> </tr> <tr> <td></td> <td>30 dB</td> <td>low</td> <td>high</td> <td>low</td> </tr> <tr> <td></td> <td>40 dB</td> <td>high</td> <td>high</td> <td>low</td> </tr> <tr> <td></td> <td>50 dB</td> <td>low</td> <td>low</td> <td>high</td> </tr> <tr> <td></td> <td>60 dB</td> <td>high</td> <td>low</td> <td>high</td> </tr> </table>	Gain Setting	Gain	Pin 10	Pin 11	Pin 12		10 dB	low	low	low		20 dB	high	low	low		30 dB	low	high	low		40 dB	high	high	low		50 dB	low	low	high		60 dB	high	low	high
Gain Setting	Gain	Pin 10	Pin 11	Pin 12																																
	10 dB	low	low	low																																
	20 dB	high	low	low																																
	30 dB	low	high	low																																
	40 dB	high	high	low																																
	50 dB	low	low	high																																
	60 dB	high	low	high																																
	<table style="width: 100%; border-collapse: collapse;"> <tr> <td style="width: 30%;">AC/DC Setting</td> <td style="width: 15%;">Coupling</td> <td style="width: 15%;">Pin 13</td> </tr> <tr style="border-top: 1px solid black; border-bottom: 1px solid black;"> <td></td> <td>AC</td> <td>low</td> </tr> <tr> <td></td> <td>DC</td> <td>high</td> </tr> </table>	AC/DC Setting	Coupling	Pin 13		AC	low		DC	high																										
AC/DC Setting	Coupling	Pin 13																																		
	AC	low																																		
	DC	high																																		
	<table style="width: 100%; border-collapse: collapse;"> <tr> <td style="width: 30%;">Bandwidth Setting</td> <td style="width: 15%;">Bandwidth</td> <td style="width: 15%;">Pin 14</td> </tr> <tr style="border-top: 1px solid black; border-bottom: 1px solid black;"> <td></td> <td>10 MHz</td> <td>low</td> </tr> <tr> <td></td> <td>100 MHz</td> <td>high</td> </tr> </table>	Bandwidth Setting	Bandwidth	Pin 14		10 MHz	low		100 MHz	high																										
Bandwidth Setting	Bandwidth	Pin 14																																		
	10 MHz	low																																		
	100 MHz	high																																		

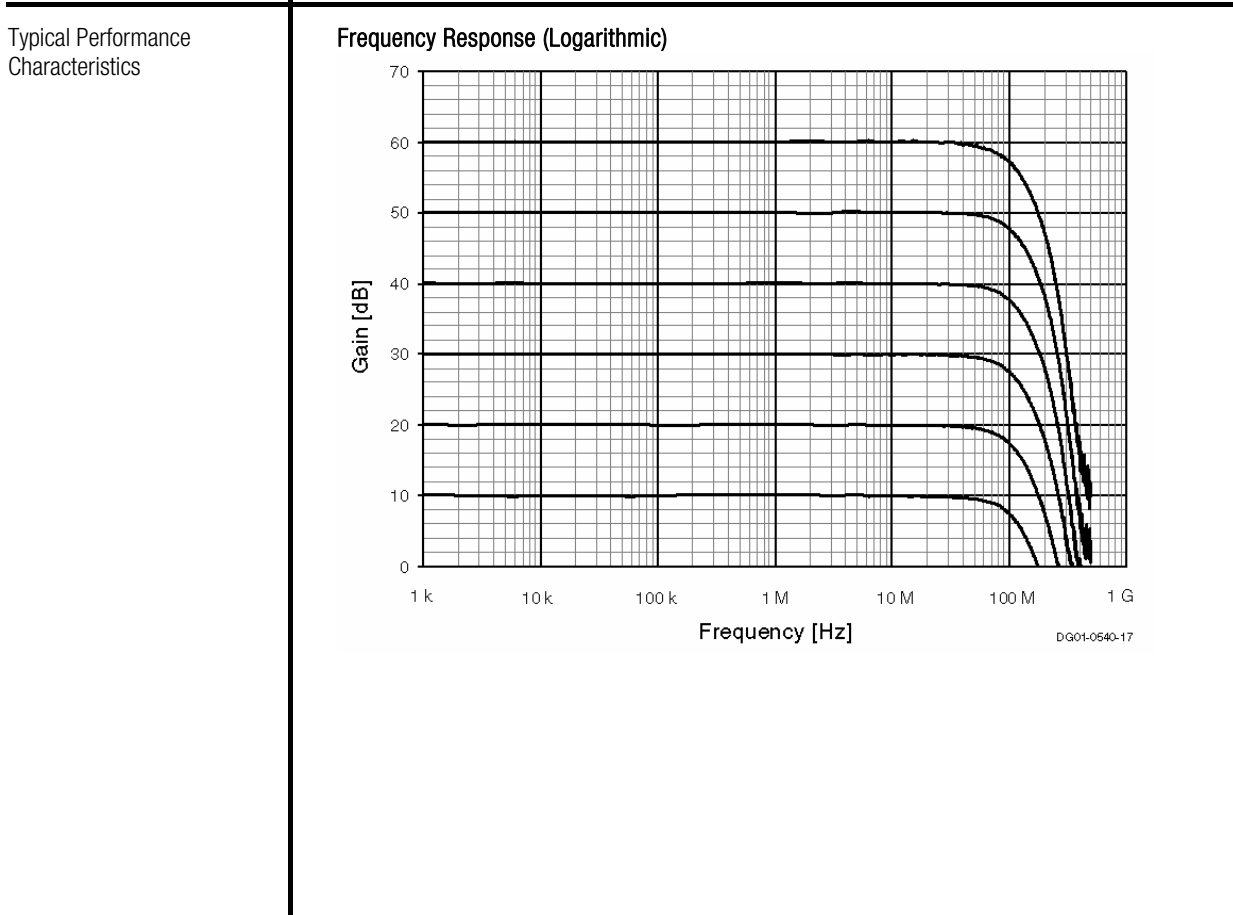

Variable Gain 100 MHz Wideband Voltage Amplifier

Dimensions

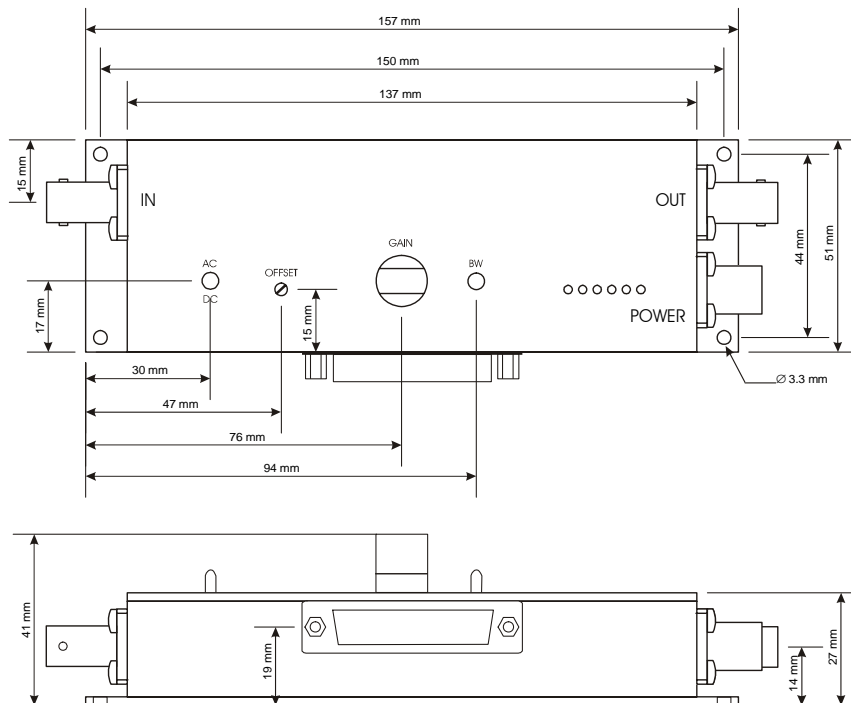

D201-0540-17

FEMTO Messtechnik GmbH
 Paul-Lincke-Ufer 34
 D-10999 Berlin · Germany
 Tel.: +49 (0)30 – 4 46 93 86
 Fax: +49 (0)30 – 4 46 93 88
 e-mail: info@femto.de
 http://www.femto.de

Specifications are subject to change without notice. Information furnished herein is believed to be accurate and reliable. However, no responsibility is assumed by FEMTO Messtechnik GmbH for its use, nor for any infringement of patents or other rights granted by implication or otherwise under any patent rights of FEMTO Messtechnik GmbH. Product names mentioned may also be trademarks used here for identification purposes only.
 © by FEMTO Messtechnik GmbH
 Printed in Germany