

## Ultra-Low-Noise Current Amplifier

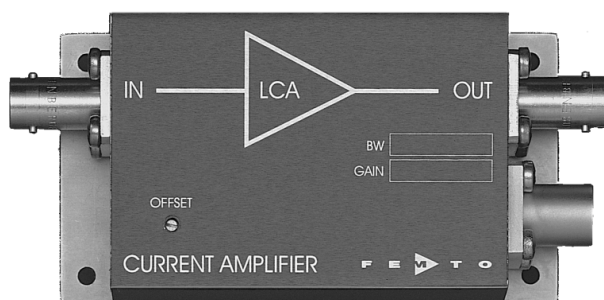

Features	<ul style="list-style-type: none"> <li>• <b>Bandwidth and Frequency Response Independent of Detector-Capacitance (up to 10 nF)</b></li> <li>• <b>Extremely Low Noise, 0.5 fA/√Hz Equivalent Input Noise Current</b></li> <li>• <b>Bandwidth DC ... 30 Hz</b></li> <li>• <b>Transimpedance (Gain) 1 x 10<sup>12</sup> V/A</b></li> </ul>																																																				
Applications	<ul style="list-style-type: none"> <li>• <b>Photodiode- and Photomultiplier-Amplifier</b></li> <li>• <b>Spectroscopy</b></li> <li>• <b>Charge-Amplifier</b></li> <li>• <b>Ionisation Detectors</b></li> <li>• <b>Preamplifier for Lock-Ins, A/D-Converters, etc.</b></li> </ul>																																																				
Specifications	<p><i>Test Conditions</i> <span style="float: right;"><i>V<sub>s</sub> = ± 15 V, T<sub>a</sub> = 25 °C</i></span></p> <table border="0" style="width: 100%;"> <tr> <td style="width: 20%;">Gain</td> <td style="width: 60%;">Transimpedance Accuracy</td> <td style="width: 20%;">1 x 10<sup>12</sup> V/A (&gt;10 kΩ Load) ± 1%</td> </tr> <tr> <td rowspan="4">Frequency Response</td> <td>Lower Cut-Off Frequency</td> <td>DC</td> </tr> <tr> <td>Upper Cut-Off Frequency</td> <td>30 Hz (- 3 dB)</td> </tr> <tr> <td>Rise- / Fall-Time</td> <td>12 ms (10% - 90%)</td> </tr> <tr> <td>Gain Flatness</td> <td>± 0.1 dB</td> </tr> <tr> <td rowspan="8">Input</td> <td>Equ. Input Noise Current</td> <td>0.5 fA/√Hz (@ 10 Hz)</td> </tr> <tr> <td>Equ. Input Noise Voltage</td> <td>90 nV/√Hz (@ 10 Hz)</td> </tr> <tr> <td>Input Bias Current</td> <td>10 fA typ.</td> </tr> <tr> <td>Input Bias Current Drift</td> <td>Factor 2 / 10 K</td> </tr> <tr> <td>Offset Current Compensation</td> <td>± 3 pA, Adjustable by Offset-Trimpot</td> </tr> <tr> <td>Max. Input Current</td> <td>± 10 pA (Linear Amplification)</td> </tr> <tr> <td>Input Offset Voltage</td> <td>&lt; 0.5 mV</td> </tr> <tr> <td>DC Input Impedance</td> <td>1 kΩ (Virtual) // 5 pF</td> </tr> <tr> <td rowspan="3">Output</td> <td>Output Voltage</td> <td>± 10 V (&gt;10 kΩ Load)</td> </tr> <tr> <td>Output Impedance</td> <td>50 Ω (Terminate with &gt;10 kΩ for best Performance)</td> </tr> <tr> <td>Max. Output Current</td> <td>± 10 mA (Linear Amplification)</td> </tr> <tr> <td rowspan="2">Power Supply</td> <td>Supply Voltage</td> <td>± 15 V</td> </tr> <tr> <td>Supply Current</td> <td>± 15 mA typ.</td> </tr> <tr> <td rowspan="2">Case</td> <td>Weight</td> <td>210 gr. (0.5 lbs)</td> </tr> <tr> <td>Material</td> <td>AlMg4.5Mn, nickel-plated</td> </tr> <tr> <td rowspan="2">Temperature Range</td> <td>Storage Temperature</td> <td>-40 ... +100 °C</td> </tr> <tr> <td>Operating Temperature</td> <td>0 ... +60 °C</td> </tr> </table>		Gain	Transimpedance Accuracy	1 x 10 <sup>12</sup> V/A (>10 kΩ Load) ± 1%	Frequency Response	Lower Cut-Off Frequency	DC	Upper Cut-Off Frequency	30 Hz (- 3 dB)	Rise- / Fall-Time	12 ms (10% - 90%)	Gain Flatness	± 0.1 dB	Input	Equ. Input Noise Current	0.5 fA/√Hz (@ 10 Hz)	Equ. Input Noise Voltage	90 nV/√Hz (@ 10 Hz)	Input Bias Current	10 fA typ.	Input Bias Current Drift	Factor 2 / 10 K	Offset Current Compensation	± 3 pA, Adjustable by Offset-Trimpot	Max. Input Current	± 10 pA (Linear Amplification)	Input Offset Voltage	< 0.5 mV	DC Input Impedance	1 kΩ (Virtual) // 5 pF	Output	Output Voltage	± 10 V (>10 kΩ Load)	Output Impedance	50 Ω (Terminate with >10 kΩ for best Performance)	Max. Output Current	± 10 mA (Linear Amplification)	Power Supply	Supply Voltage	± 15 V	Supply Current	± 15 mA typ.	Case	Weight	210 gr. (0.5 lbs)	Material	AlMg4.5Mn, nickel-plated	Temperature Range	Storage Temperature	-40 ... +100 °C	Operating Temperature	0 ... +60 °C
Gain	Transimpedance Accuracy	1 x 10 <sup>12</sup> V/A (>10 kΩ Load) ± 1%																																																			
Frequency Response	Lower Cut-Off Frequency	DC																																																			
	Upper Cut-Off Frequency	30 Hz (- 3 dB)																																																			
	Rise- / Fall-Time	12 ms (10% - 90%)																																																			
	Gain Flatness	± 0.1 dB																																																			
Input	Equ. Input Noise Current	0.5 fA/√Hz (@ 10 Hz)																																																			
	Equ. Input Noise Voltage	90 nV/√Hz (@ 10 Hz)																																																			
	Input Bias Current	10 fA typ.																																																			
	Input Bias Current Drift	Factor 2 / 10 K																																																			
	Offset Current Compensation	± 3 pA, Adjustable by Offset-Trimpot																																																			
	Max. Input Current	± 10 pA (Linear Amplification)																																																			
	Input Offset Voltage	< 0.5 mV																																																			
	DC Input Impedance	1 kΩ (Virtual) // 5 pF																																																			
Output	Output Voltage	± 10 V (>10 kΩ Load)																																																			
	Output Impedance	50 Ω (Terminate with >10 kΩ for best Performance)																																																			
	Max. Output Current	± 10 mA (Linear Amplification)																																																			
Power Supply	Supply Voltage	± 15 V																																																			
	Supply Current	± 15 mA typ.																																																			
Case	Weight	210 gr. (0.5 lbs)																																																			
	Material	AlMg4.5Mn, nickel-plated																																																			
Temperature Range	Storage Temperature	-40 ... +100 °C																																																			
	Operating Temperature	0 ... +60 °C																																																			
Absolute Maximum Ratings	<table border="0" style="width: 100%;"> <tr> <td style="width: 60%;">Input Voltage</td> <td style="width: 40%;">± 10 V</td> </tr> <tr> <td>Power Supply Voltage</td> <td>± 22 V</td> </tr> </table>		Input Voltage	± 10 V	Power Supply Voltage	± 22 V																																															
Input Voltage	± 10 V																																																				
Power Supply Voltage	± 22 V																																																				

# Ultra-Low-Noise Current Amplifier

Connectors

Input BNC  
 Output BNC  
 Power Supply LEMO Series 1S, 3-pin Fixed Socket  
 Pin 1: + 15V  
 Pin 2: - 15V  
 Pin 3: GND

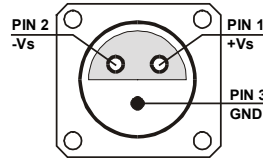

Application Diagrams

Photo Detector Biasing in Photovoltaic Mode:  
 Use for Low Speed Applications and Minimum Dark Current.

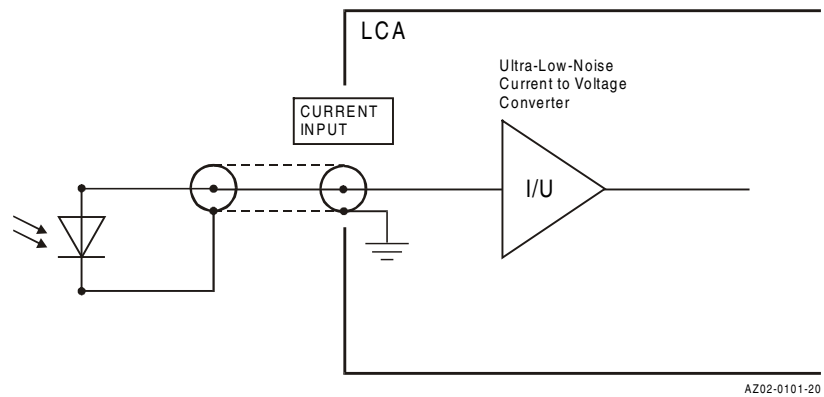
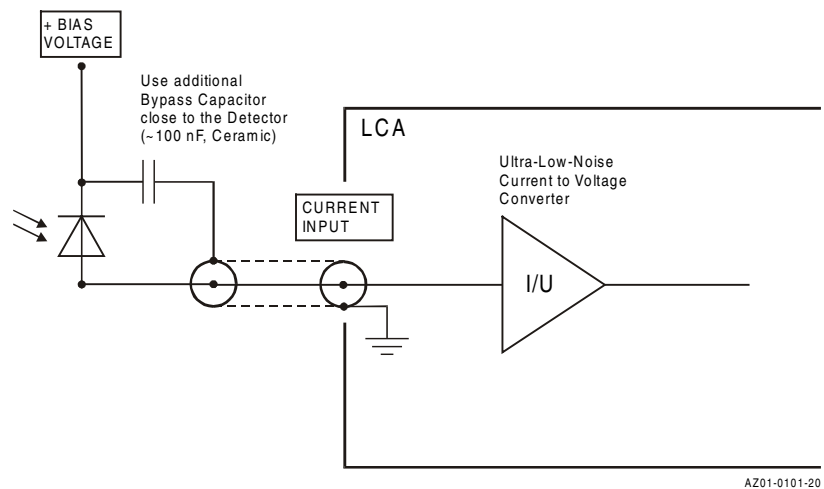
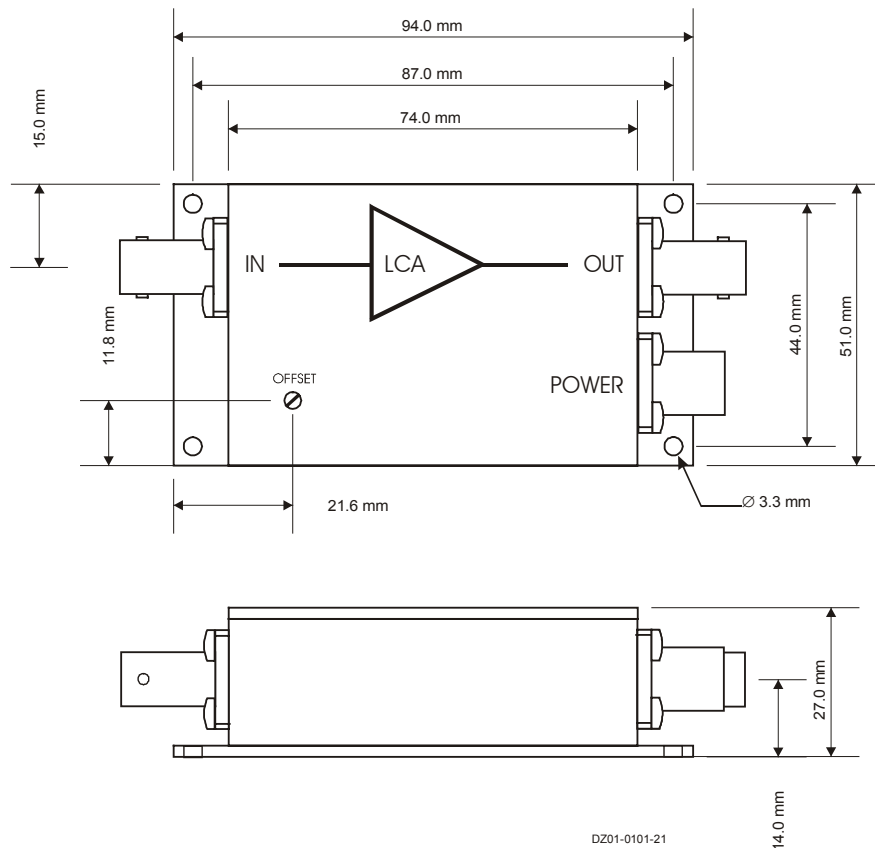

Photo Detector Biasing in Photoconductive Mode:  
 Use for Fast Applications and if More Dark Current is Tolerable.  
 Bias Voltage Decreases Detector Capacitance.



Ultra-Low-Noise Current Amplifier

Dimensions



DZ01-0101-21

FEMTO Messtechnik GmbH  
 Paul-Lincke-Ufer 34  
 D-10999 Berlin · Germany  
 Tel.: +49 (0)30 – 4 46 93 86  
 Fax: +49 (0)30 – 4 46 93 88  
 e-mail: info@femto.de  
 http://www.femto.de

Specifications are subject to change without notice. Information furnished herein is believed to be accurate and reliable. However, no responsibility is assumed by FEMTO Messtechnik GmbH for its use, nor for any infringement of patents or other rights granted by implication or otherwise under any patent rights of FEMTO Messtechnik GmbH. Product names mentioned may also be trademarks used here for identification purposes only.  
 © by FEMTO Messtechnik GmbH  
 Printed in Germany