

SiC - photodiode JEC 0,3I



- characteristics :**
- ◆ spectral range 210 ... 380 nm
 - ◆ active area 0,22 mm²
 - ◆ high UV - response 0,13 A/W
 - ◆ TO 39-package
 - ◆ photodiode isolated to package
 - ◆ components are in conformity with RoHS and WEEE

- applications :**
- ◆ UV-measurement only
 - ◆ UV-source control (for instance in sterilizers)
 - ◆ flamedetection

maximum ratings:

maximum reverse voltage	20	V
operating temperature range - 25 °C ... 70		°C
storage temperature range -40 °C ... 100		°C
soldering temperature (3s)	260	°C

technical data :

test conditions, as not otherwise specified: $\gamma_a = 25 \text{ °C}$, $V_R = 0V$

parameters	test conditions	min.	typ.	max.	unit
active area			0,5 x 0,5		mm ²
spectral range		210		380	nm
maximum of spectral responsivity	$\lambda_{max} = 275 \text{ nm}$		0,13		A/W
absolute spectral responsivity	$\lambda = 254 \text{ nm}$		0,11		A/W
dark current I_R	$V_R = 1 \text{ V}$		5		fA
capacitance			80		pF

rev3 (3/2009)

For more information:

Electro Optical Components, 5460 Skyline Blvd., Santa Rosa, CA 95403
Phone: (707) 568-1642 | Fax: (707) 568-1652 | Email: info@eoc-inc.com

D
A
T
A

S
H
E
E
T

relative spectral response

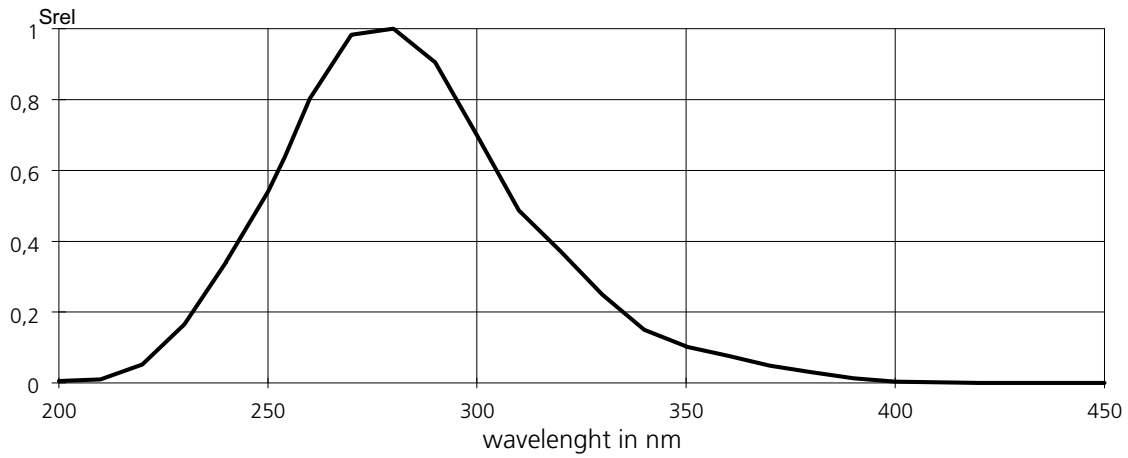

package dimensions

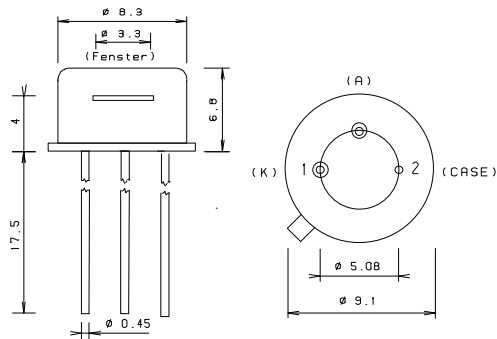

application example

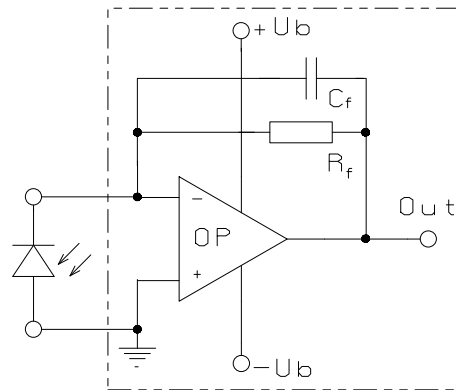

The application example shows a typical circuit. R_f is responsible for the gain of the circuit. C_f compensates the reverse junction capacitance of the photodiode and input capacitance of the OPV. The exact value of C_f depends on R_f , used OPV and capacitance of the circuit. A typical value is 1 pF.

The diagram shows dependence of amplitude of the application circuit with OPA 111, $R_f = 50 \text{ M}\Omega$ and $C_f = 0.5 \text{ pF}$.

