

SiC – photodiode

JEC 0,3 IS
JEC 0,3 ISZ



- characteristics :**
- ◆ spectral range 210 ... 380 nm
 - ◆ active area 0,22 mm²
 - ◆ high UV - responsivity 0,13 A/W
 - ◆ TO 18-package
 - ◆ sensor isolated to package
 - ◆ components are in conformity with RoHS and WEEE

- applications :**
- ◆ UV-measurement only
 - ◆ control of sterilization lamps
 - ◆ flame detection

absolute maximum ratings:

reverse voltage	20	V
operating temperature range	- 25 °C ... 70	°C
storage temperature range	-40 °C ... 100	°C
soldering temperature (3s)	260	°C

technical data :

test conditions, as not otherwise specified: $\gamma_a = 25\text{ °C}$, $V_R = 0V$

parameter	test condition	min.	typ.	max.	unit
active area			0,5 x 0,5		mm ²
spectral range		210		380	nm
maximum of spectral responsivity	$\lambda_{max} = 275\text{ nm}$		0,13		A/W
absolute spectral responsivity	$\lambda = 254\text{ nm}$		0,11		A/W
dark current I_R	$V_R = 1\text{ V}$		5		fA
capacitance			80		pF

rev3 (03/2009)

For more information:

Electro Optical Components, 5460 Skyline Blvd., Santa Rosa, CA 95403
Phone: (707) 568-1642 | Fax: (707) 568-1652 | Email: info@eoc-inc.com

D
A
T
A

S
H
E
E
T

JEC 0,3 IS; JEC 0,3 ISZ

relative spectral responsivity

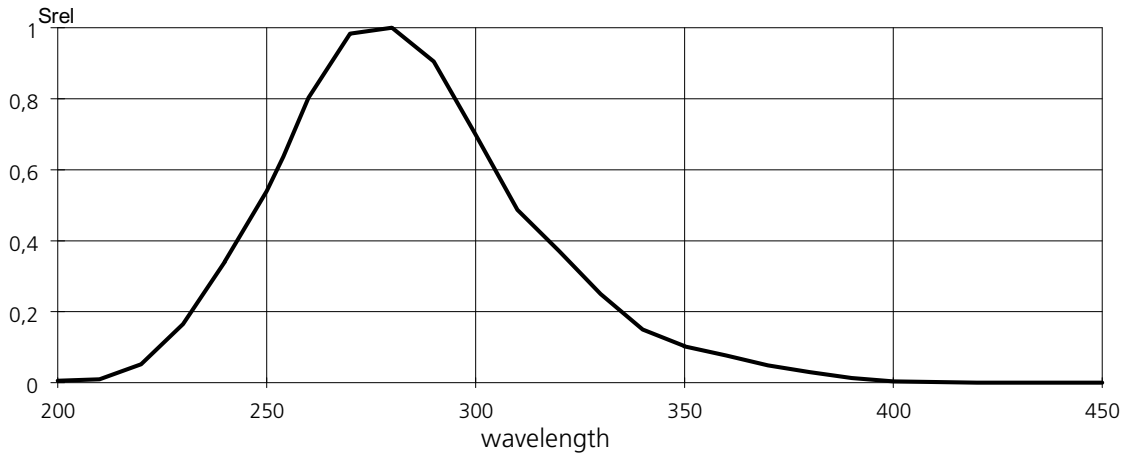

package dimensions

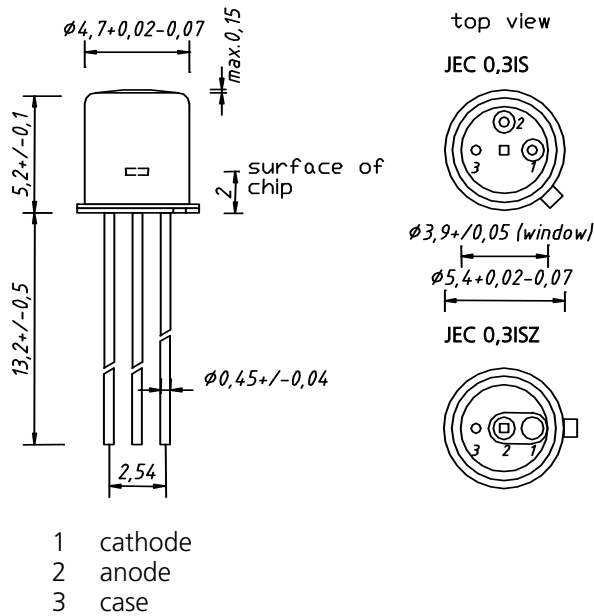

application example

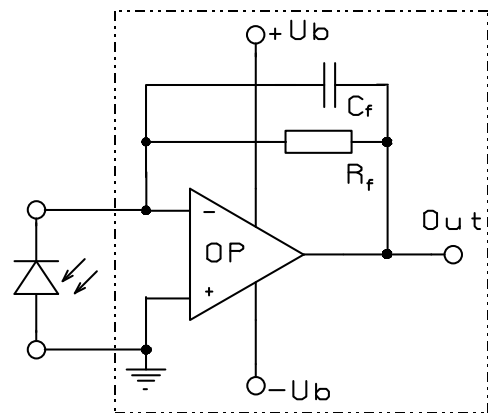

The application example shows a typical circuit. R_f is responsible for the gain of the circuit. C_f compensates the reverse junction capacitance of the photodiode and input capacitance of the OPV. The exact value of C_f depends on R_f , used OPV and capacitance of the circuit. A typical value is 1 pF.

The diagram shows dependence of amplitude of the application circuit with OPA 111, $R_f = 50 \text{ M}\Omega$ and $C_f = 0.5 \text{ pF}$.

