

# SiC – photodiode

JEC 1 IS  
JEC 1 ISZ



- characteristics :**
- ◆ spectral range 210 ... 380 nm
  - ◆ active area 0,965 mm<sup>2</sup>
  - ◆ high UV-responsivity 0,16 A/W
  - ◆ TO 18-package
  - ◆ photodiode isolated to package
  - ◆ components are in conformity with RoHS and WEEE

- applications :**
- ◆ UV-measurements only
  - ◆ UV-source control
  - ◆ flame detection

## maximum ratings:

reverse voltage	20	V
operation temperature range	- 25 °C ... 70	°C
storage temperature range	-40 °C ... 100	°C
soldering temperature (3s)	260	°C

## technical data :

test conditions, as not otherwise specified:  $\gamma_a = 25 \text{ °C}$ ,  $V_R = 0V$

parameters	test conditions	min.	typ.	max.	unit
active area			1 x 1		mm <sup>2</sup>
spectral range		210		380	nm
maximum of spectral responsivity	$\lambda_{\max} = 275 \text{ nm}$		0,16		A/W
absolute spectral responsivity	$\lambda = 254 \text{ nm}$		0,14		A/W
dark current $I_R$	$V_R = 1 \text{ V}$		2		fA
short current (sun light)	bright sun cloudy		1 0,4		$\mu\text{A}$
capacitance			195		pF

rev3 (03/2009)

For more information:

Electro Optical Components, 5460 Skyline Blvd., Santa Rosa, CA 95403  
Phone: (707) 568-1642 | Fax: (707) 568-1652 | Email: info@eoc-inc.com

D  
A  
T  
A  
  
S  
H  
E  
E  
T

## relative spectral responsivity

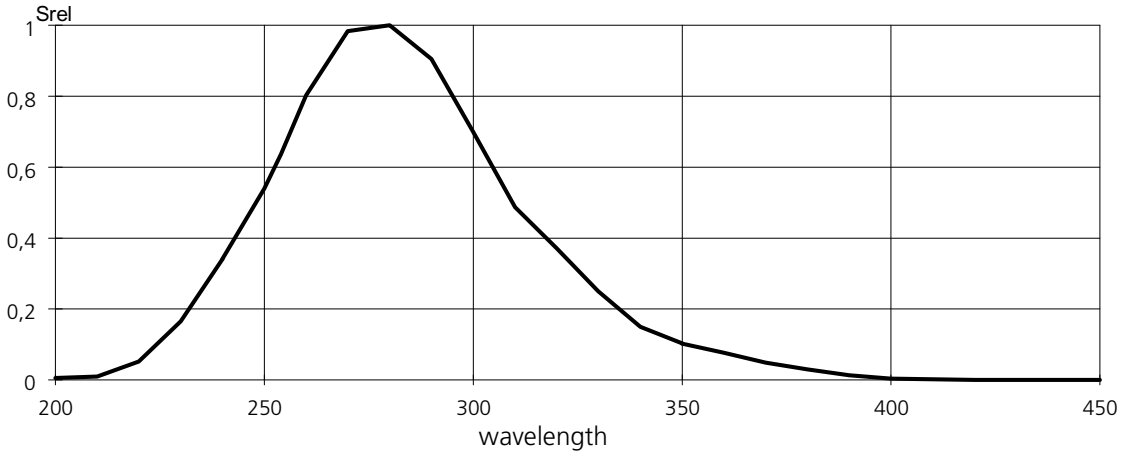

## package dimensions

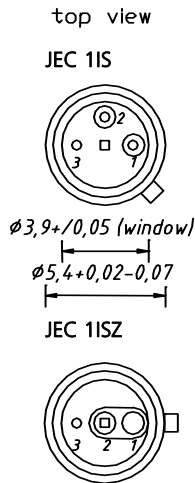
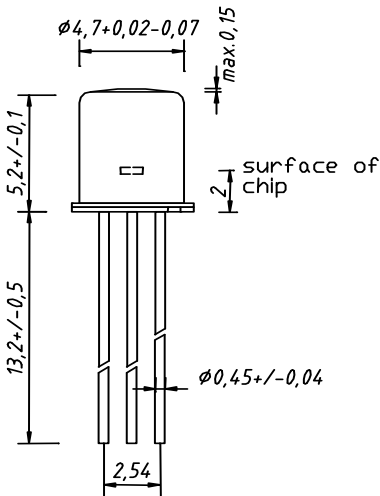

- 1 cathode
- 2 anode
- 3 case

## application example

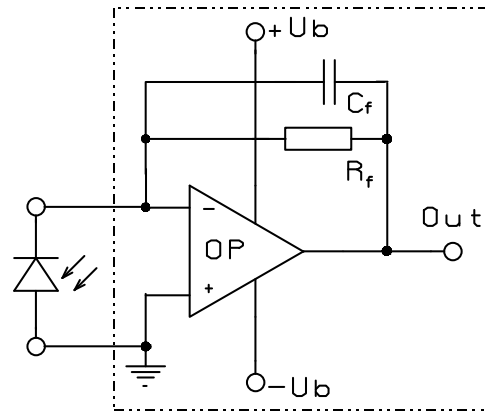

The application example shows a typical circuit.  $R_f$  is responsible for the gain of the circuit.  $C_f$  compensates the reverse junction capacitance of the photodiode and input capacitance of the OPV. The exact value of  $C_f$  depends on  $R_f$ , used OPV and capacitance of the circuit. A typical value is 1 pF.

The diagram shows dependence of amplitude of the application circuit with OPA 111,  $R_f = 50 \text{ M}\Omega$  and  $C_f = 0.5 \text{ pF}$ .

