

UV-Photodetector JI 100 EI 8UV-T1H



- characteristics :**
- ◆ spectral range 190 ... 1100 nm
 - ◆ active area 100 mm²
 - ◆ integrated amplifier
 - ◆ integrated cooler and temperature sensor
 - ◆ sensor isolated to case
 - ◆ very low noise level
 - ◆ components are in conformity with RoHS and WEEE

- applications :**
- ◆ UV-NIR-spectroscopy
 - ◆ broadband measuring detector

absolute maximum ratings:

operating voltage	± 18	V
power consumption	180	mW
operating temperature range	0 °C ... 70	°C
storage temperature range	-25 °C ... 100	°C
soldering temperature (3s)	260	°C

technical data :

test conditions, as not otherwise specified: $\gamma_a = 25\text{ °C}$, $V_{cc} = \pm 15\text{V}$

parameter	test condition	min.	typ.	max.	unit
active area			10 x 10		mm ²
dark offset voltage			± 0,25	± 0,5	mV
drifting of offsett voltage	$\gamma_a = 22\text{ °C}$ $\gamma_u = 15...35\text{ °C}$			± 5	µV/K
saturation voltage			12,5		V
feedback resistor		19	20	21	MΩ
operation voltage		±5	±15	±18	V
operating current	dark value		± 1,5		mA
rise time (with optimal ecternal compensation)	$\lambda = 870\text{ nm}$		150		µs
bandwidth	- 3 dB		2		kHz
resistance of thermistor	$\gamma_a = 25\text{ °C}$	9,8	10	10,2	kΩ
temp. coeff. of thermistor	$\gamma_a = 25\text{ °C}$		-4,4		%
voltage of cooler				1,7	V
current of cooler				2	A

rev2 (03/2009)

For more information:

Electro Optical Components, 5460 Skyline Blvd., Santa Rosa, CA 95403
Phone: (707) 568-1642 | Fax: (707) 568-1652 | Email: info@eoc-inc.com

D
A
T
A

S
H
E
E
T

JI 100 EI 8UV-T1H

relative spectral response

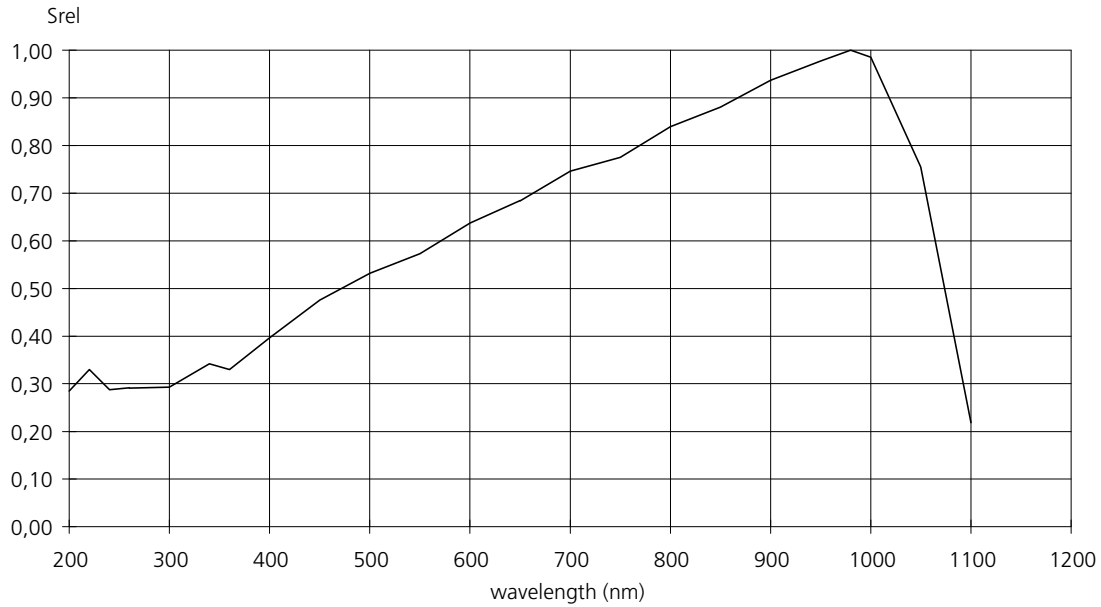

pin configuration

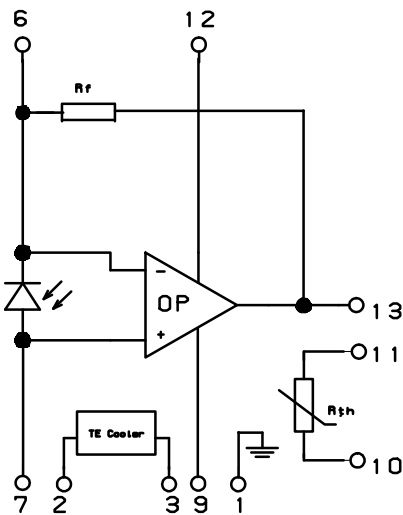

package

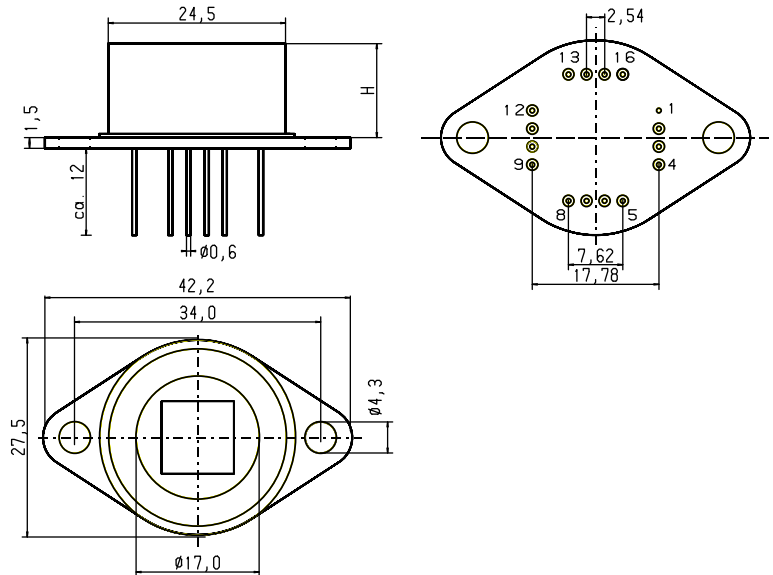

- | | |
|---------------|---------------|
| 1 case | 9 V_{CC-} |
| 2 TE-cooler - | 10 thermistor |
| 3 TE-cooler + | 11 thermistor |
| 4 n.c. | 12 V_{CC+} |
| 5 n.c. | 13 Out |
| 6 R_{f1} | 14 n.c. |
| 7 GND | 15 n.c. |
| 8 n.c. | 16 n.c. |

Option H

H = 11,0 mm

application hint assembly option Rf, i.e. adjustable feedback resistor on request