

Si - photodiode with integrated amplifier

JI 576
JI 577
JI 578



- characteristics :**
- ◆ Si-photodiode with integrated low noise JFET-amplifier
 - ◆ integrated feedback resistor and capacitor
 - ◆ decadic staggered responsivity
 - ◆ spectral range VIS and NIR
 - ◆ very low offset- and driftparameters
 - ◆ high dynamic range
 - ◆ duale power supply
 - ◆ hermetically sealed TO-5 package
 - ◆ assembly isolated to ground
 - ◆ replacement type for JI 7/JI 7,5 (not pincompatible!)
 - ◆ components are in conformity with RoHS and WEEE

- applications :**
- ◆ common light-/radiation measuring applications
 - ◆ detector for measuring of low radiation intensities with high signal to noise level
 - ◆ spectroscopy
 - ◆ medical diagnostics

- maximum ratings :**
- ◆ operating voltage ±18 V
 - ◆ operating temperature range -25 °C ... +85 °C
 - ◆ storage temperature range -40 °C ... +100 °C
 - ◆ welding temperature (3s) 260 °C

technical data :

common test conditions, as not otherwise specified: $T_A = 25\text{ °C}$, $V_S = \pm 15\text{ V}$
typ. data, maximum data in brackets

parameter	testcondition	JI 576	JI 577	JI 578	unit
active area		7			mm ²
feedback resistor		1	10	100	MΩ
dark offset voltage	E = 0 lx	± 0,3 (±0,75)	± 0,3 (±0,75)	± 2,0 (±0,75)	mV
noise voltage	B = 20 kHz	0,2	0,3	0,5	mV _{rms}
spectral range	$S=0,1 \cdot S_{max}$	400...1100			nm
max. of spectral responsivity	$S=S_{max}$	850			nm
max. spectral responsivity	$S=S_{max}$	0,6	6	60	mV/nW
rise time		3,5	20	50	μs
bandwidth	- 3 dB	100	18	7	kHz
opening angle	$S(\varphi)=0,5 \cdot S_{max} \cdot \cos(\varphi)$	± 50			Grad
saturation voltage	$R_L = 2\text{ k}\Omega$	-14,8 (-14,5)			V
short current		± 45			mA
operation voltage		± 5...± 15			V
current consumption		2,2 (2,6)			mA

rev2 (03/2009)

For more information:

Electro Optical Components, 5460 Skyline Blvd., Santa Rosa, CA 95403
Phone: (707) 568-1642 | Fax: (707) 568-1652 | Email: info@eoc-inc.com

DATA SHEET

J1 576, J1 577, J1 578

relative spectral responsivity

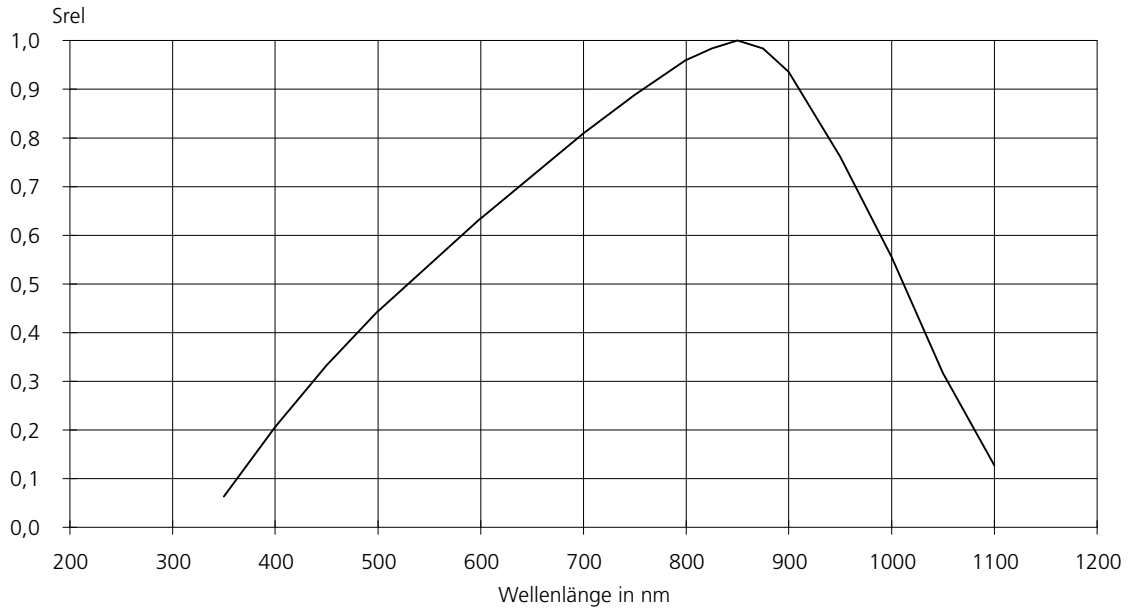

internal circuit

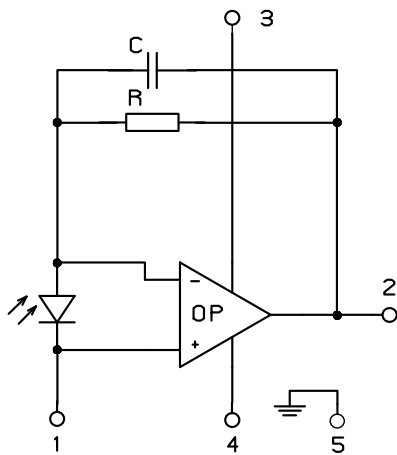

- 1 GND
- 2 Out
- 3 +V_s
- 4 -V_s
- 5 Case

package dimensions

