

Quadrant - Photodiode JQI 5P, JQI 20P and JQI 50P with integrated amplifier



- characteristics :**
- ◆ Si - PIN - Photodiode
 - ◆ spektral range 360 ... 1060 nm
 - ◆ active area 5, 20 u..50 mm²
 - ◆ possible solution of position 0,1 μm

- application :**
- ◆ adjustment detector
 - ◆ star leading detector in astronomic equipment

absolute maximum ratings:

operating voltage	± 18	V
power consumption	300	mW
operating temperature range	- 25 °C ... 70	°C
storage temperature	- 40 °C ... 85	°C
welding temperature (3s)	260	°C

technical data :

common measuring conditions, as not otherwise specified: $\gamma_a = 25 \text{ °C}$, $V_{CC} = \pm 15 \text{ V}$

parameter	test condition	JQI 5P	JQI 20P	JQI 50P	units
active area		4 x 1,25	4 x 5	4 x 12,5	mm ²
dark offset voltage	E = 0 lx	typ. ±1, max. ±3			mV
saturation voltage		- 13,5			V
noise voltage	B = 15 kHz	typ. 1, max. 2,5			mV _{rms}
absolute spectral responsivity	$\lambda = 850 \text{ nm}$	55			mV/μW
feedback resistor		100			kΩ
operating voltage		min. ±5, typ. ±15, max. ±18			V
operating current		± 2,5			mA
rise-/falltime		40	50	65	μs
bandwidth	- 3 dB	30	15	6	kHz

rev. 4(03/2009)

For more information:

Electro Optical Components, 5460 Skyline Blvd., Santa Rosa, CA 95403
Phone: (707) 568-1642 | Fax: (707) 568-1652 | Email: info@eoc-inc.com

DATA SHEET

JQI 5P, JQI 20P, JQI 50P

relative spectral responsivity

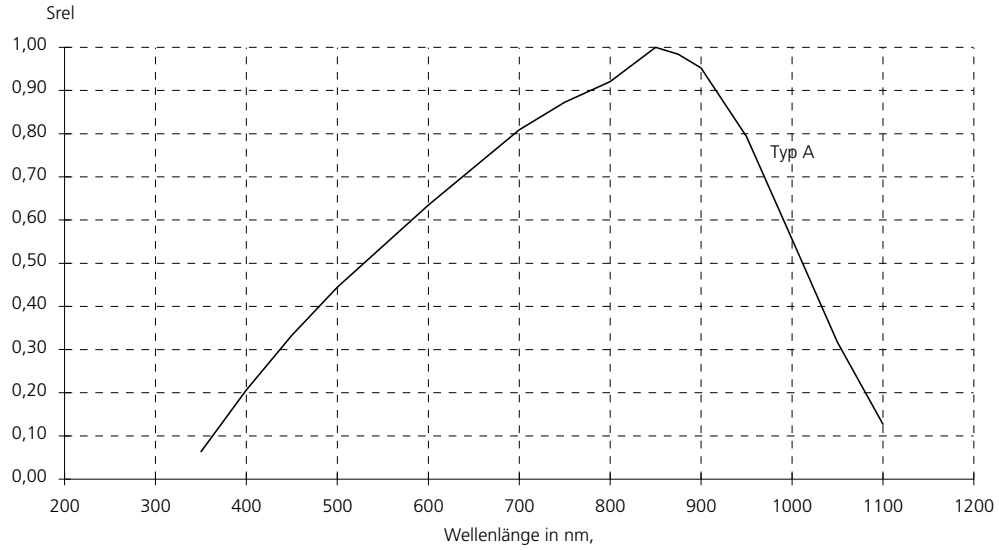

internal circuit

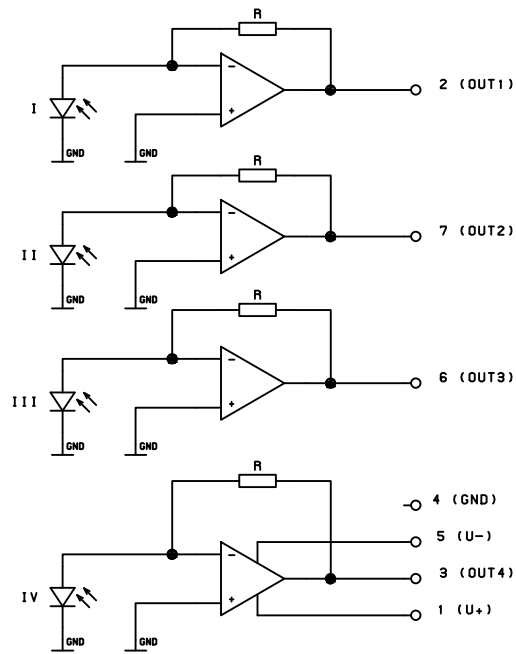

package

