

LED lamp

ELD-770-524-1

Radiation	Type	Technology	Case
Infrared	Water clear	AlGaAs/AlGaAs	5 mm plastic lens

Preliminary data

Description

High-power, high-speed, double heterostructure with removed substrate, chip with central contact, housing without standoff leads

Applications

Optical communications, safety equipment, automation

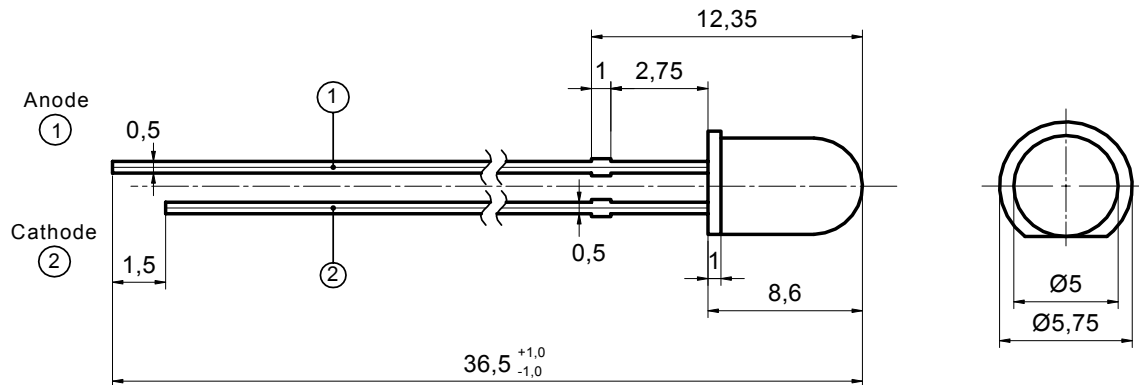

Note: Special packages with standoff available on request

Maximum Ratings

$T_{amb} = 25^{\circ}\text{C}$, unless otherwise specified

Parameter	Test conditions	Symbol	Value	Unit
Forward current (DC)		I_F	50	mA
Peak forward current	$(t_p \leq 50 \mu\text{s}, t_p/T = 1/2)$	I_{FM}	100	mA
Surge forward current	$(t_p \leq 10 \mu\text{s})$	I_{FSM}	1000	mA
Reverse voltage	$I_R = 100 \mu\text{A}$	V_R	5	V
Operating temperature range		T_{amb}	-20 to +100	$^{\circ}\text{C}$
Storage temperature range		T_{stg}	-55 to +100	$^{\circ}\text{C}$

Optical and Electrical Characteristics

$T_{amb} = 25^{\circ}\text{C}$, unless otherwise specified

Parameter	Test conditions	Symbol	Min	Typ	Max	Unit
Forward voltage	$I_F = 50 \text{ mA}$	V_F		2.0	2.4	V
Radiant power	$I_F = 50 \text{ mA}$	Φ_e	8	14		mW
Radiant intensity	$I_F = 50 \text{ mA}$	I_e	40	70		mW/sr
Peak wavelength	$I_F = 20 \text{ mA}$	λ_p	760	770	780	nm
Spectral bandwidth at 50%	$I_F = 50 \text{ mA}$	$\Delta\lambda_{0.5}$		30		nm
Viewing angle	$I_F = 50 \text{ mA}$	2φ		20		deg.
Switching time	$I_F = 100 \text{ mA}$	t_r, t_f		35		ns

rev.10/04