

# INFRARED LASER DIODE

## DL-8031-031

## Tentative

# SANYO

Ver.2 Jan. 2003

### Features

- Lasing wavelength : 808 nm (Typ.)
- Single longitudinal mode
- High output power : 150 mW at 50°C
- Low threshold current : I<sub>th</sub> = 50 mA (Typ.)
- Fundamental transverse mode

### Applications

- Solid state laser pumping

### Absolute Maximum Ratings

(T<sub>c</sub>=25°C)

Parameter		Symbol	Ratings	Unit
Light Output	CW	P <sub>o</sub>	160	mW
Reverse Voltage	Laser	V <sub>R</sub>	2	V
	PD		30	
Operating Temperature		T <sub>opr</sub>	-10 to +50	°C
Storage Temperature		T <sub>stg</sub>	-40 to +85	°C

### Electrical and Optical Characteristics <sup>1) 2)</sup>

(T<sub>c</sub>=25°C)

Parameter		Symbol	Condition	Min.	Typ.	Max.	Unit
Threshold Current		I <sub>th</sub>	CW	-	50	70	mA
Operating Current		I <sub>op</sub>	P <sub>o</sub> =150mW	-	180	220	mA
Operating Voltage		V <sub>op</sub>	P <sub>o</sub> =150mW	-	2.0	2.4	V
Lasing Wavelength *		L <sub>p</sub>	P <sub>o</sub> =150mW	798	808	818	nm
Beam <sup>3)</sup> Divergence	Perpendicular	Q <sub>v</sub>	P <sub>o</sub> =150mW	12	16	20	°
	Parallel	Q <sub>h</sub>	P <sub>o</sub> =150mW	6	8	10	°
Off Axis Angle	Perpendicular	dQ <sub>v</sub>	-	-	-	± 3	°
	Parallel	dQ <sub>h</sub>	-	-	-	± 3	°
Differential Efficiency		dP <sub>o</sub> /dI <sub>op</sub>	-	0.8	1.1	-	mW/mA
Monitoring Output Current		I <sub>m</sub>	P <sub>o</sub> =150mW	0.2	0.4	0.6	mA
Astigmatism		A <sub>s</sub>	P <sub>o</sub> =150mW	-	3	-	μm

- 1) Initial values      2) All the above values are evaluated with Tottori Sanyo's measuring apparatus  
 3) Full angle at half maximum

Note : The above product specification are subject to change without notice.

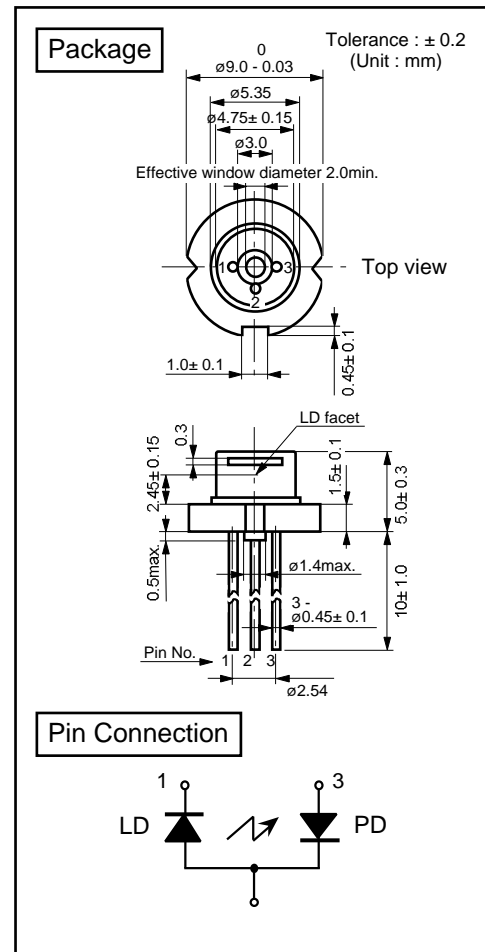

Distributed by IMM Meßtechnologie GmbH