

INFRARED LASER DIODE

DL-8141-035

SANYO

Ver.4 Mar. 2006

Features

- Lasing wavelength : 808 nm (Typ.)
- Single longitudinal mode
- High output power : 150 mW at 50°C
- Low threshold current : I_{th} = 50 mA (Typ.)
- Fundamental transverse mode
- Small package : ø5.6mm

Applications

- Solid state laser pumping

Absolute Maximum Ratings

(T_c=25°C)

Parameter		Symbol	Ratings	Unit
Light Output	CW	P _o	160	mW
Reverse Voltage	Laser	V _R	2	V
	PD		30	
Operating Temperature		T _{opr}	-10 to +50	°C
Storage Temperature		T _{stg}	-40 to +85	°C

Electrical and Optical Characteristics ^{1) 2)}

(T_c=25°C)

Parameter		Symbol	Condition	Min.	Typ.	Max.	Unit
Threshold Current		I _{th}	CW	-	50	70	mA
Operating Current		I _{op}	P _o =150mW	-	185	240	mA
Operating Voltage		V _{op}	P _o =150mW	-	2.0	2.4	V
Lasing Wavelength *		L _p	P _o =150mW	798	808	818	nm
Beam ³⁾ Divergence	Perpendicular	Q _v	P _o =150mW	12	16	20	°
	Parallel	Q _h	P _o =150mW	6	8	10	°
Off Axis Angle	Perpendicular	dQ _v	-	-3	-	3	°
	Parallel	dQ _h	-	-3	-	3	°
Differential Efficiency		SE	-	0.8	1.1	-	mW/mA
Monitoring Output Current		I _m	P _o =150mW	0.1	0.5	1.0	mA

- 1) Initial values 2) All the above values are evaluated with Tottori Sanyo's measuring apparatus
 3) Full angle at half maximum

Note : The above product specification are subject to change without notice.

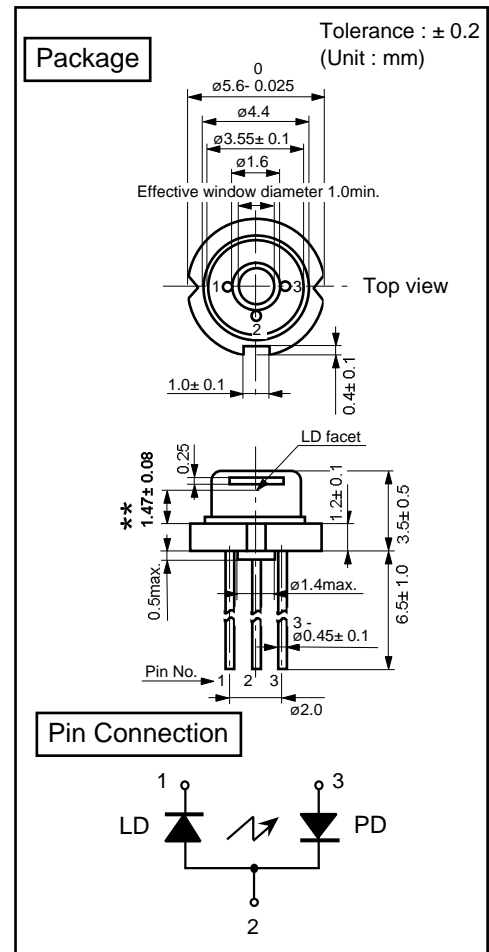

Distributed by: IMM Meßtechnologie GmbH

Ohmstr. 4, 85716 Unterschleißheim, Tel.: +49 89 321412-0, Fax: +49 89 321412-11, www.imm-laser.de, info@imm-laser.de

* Lasing Wavelength Selection Classification

Type	Lasing Wavelength (nm)
DL-8141-035A	808 ± 3
DL-8141-035B	808 ± 5
DL-8141-035C	808 ± 10