

INFRARED LASER DIODE

DL-8142-201

SANYO

Ver.1 Oct. 2006

Features

- Lasing wavelength : 830 nm (Typ.)
- High output power : 150 mW at 50°C
- Threshold current : I_{th} = 50 mA (Typ.)
- Package : ø5.6mm

Applications

- Printing instrument
- Measuring instrument

Absolute Maximum Ratings

(T_c=25°C)

Parameter		Symbol	Ratings	Unit
Light Output	CW	P _o	180	mW
Reverse Voltage	Laser	V _R	2	V
	PD		30	
Operating Temperature ¹⁾		T _{opr}	-10 to +50	°C
Storage Temperature		T _{stg}	-40 to +85	°C

1) Case temperature

Usage condition

CW: ≤ 150mW

Electrical and Optical Characteristics^{2) 3) 4) 6)}

(T_c=25°C)

Parameter		Symbol	Condition	Min.	Typ.	Max.	Unit
Threshold Current		I _{th}	CW	-	50	70	mA
Operating Current		I _{op}	P _o =150mW	-	200	250	mA
Operating Voltage		V _{op}	P _o =150mW	-	1.9	2.2	V
Lasing Wavelength		L _p	P _o =150mW	815	830	840	nm
Beam ⁵⁾ Divergence	Perpendicular	Q _v	P _o =150mW	12	16	25	°
	Parallel	Q _h	P _o =150mW	5	8	11	°
Off Axis Angle	Perpendicular	dQ _v	P _o =150mW	-3	-	3	°
	Parallel	dQ _h	P _o =150mW	-3	-	3	°
Differential Efficiency		SE	-	0.7	1.0	-	mW/mA
Monitoring Output Current		I _m	P _o =150mW	0.15	0.4	1.0	mA

2) Initial values. 3) All the above values are evaluated with Tottori sanyo's measuring apparatus.

4) Reference values. 5) Full angle at half maximum. 6) Measured at CW.

Note : The above product specification are subject to change without notice.

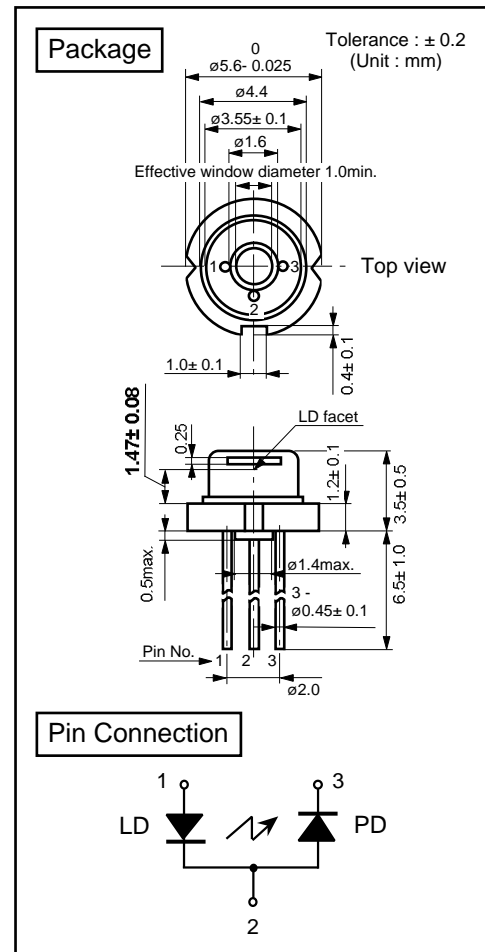

Distributed by IMM Meßtechnologie GmbH

Ohmstraße 4, D-85716 Unterschleißheim, Tel.: +49 89 321412-0, Fax: +49 89 321412-11, www.imm-laser.de, info@imm-laser.de

Characteristics

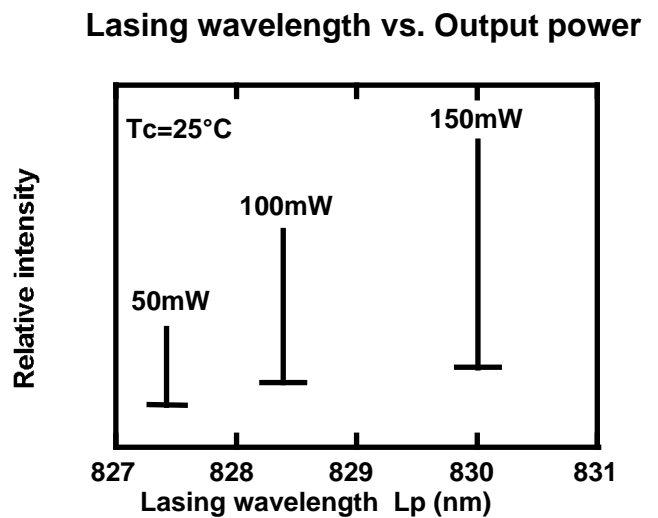
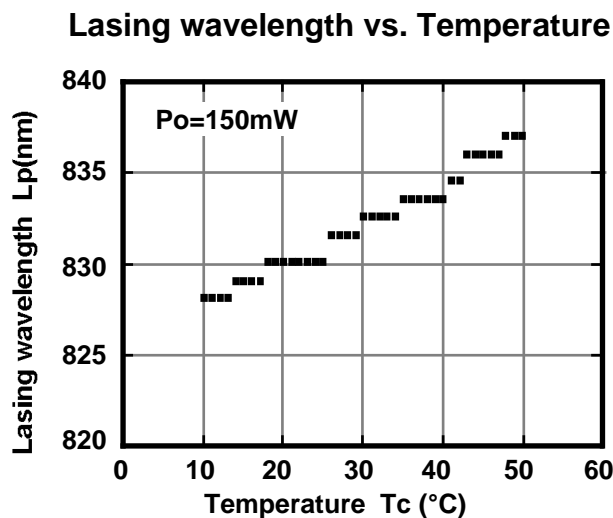
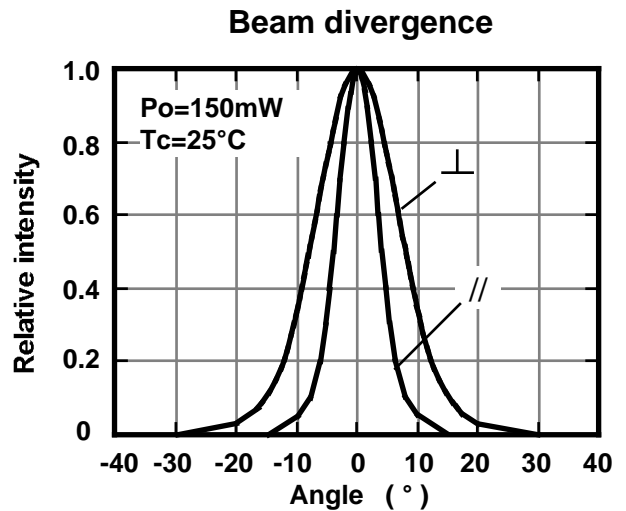
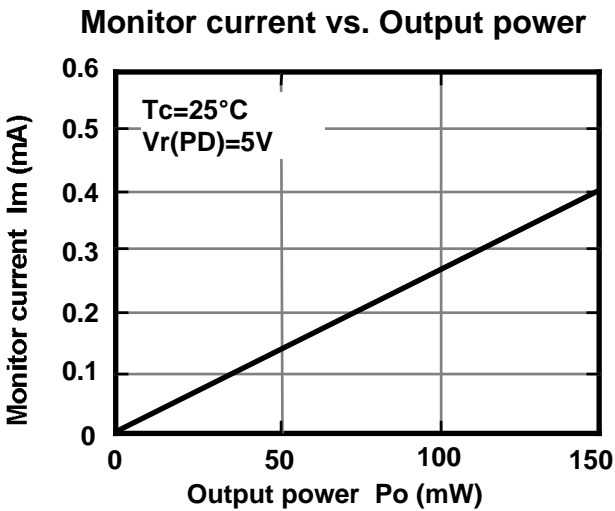
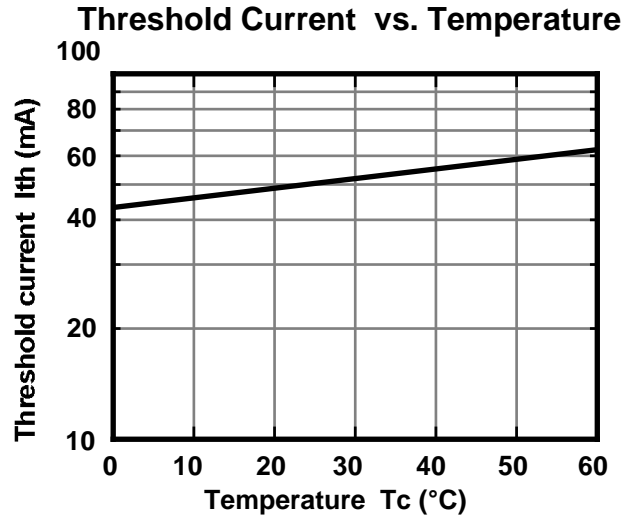
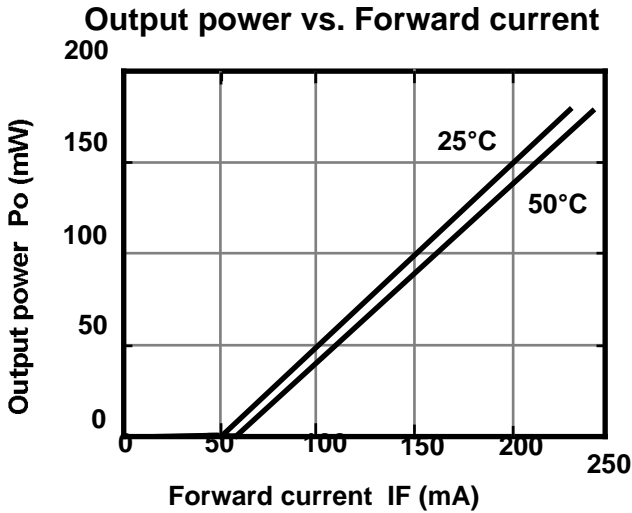

* T_c : Case temperature

This is typical data and it may not represent all products.