

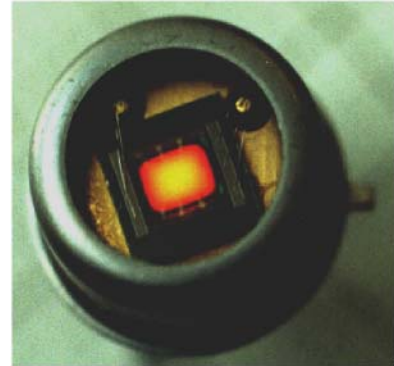

Pulsed Broadband Infrared Light Source MIRL17-900

Intex has developed a series of unique high-intensity pulsed infrared (IR) light sources capable of operating at high frequencies. Modulation of the light output is achieved by modulating the input electrical power, eliminating moving parts. The emission spectrum is that of a black body. The IR sources are based on patented thin membranes (2 microns thick) as thermoresistive elements. High emissivity, high thermal conductivity and low thermal mass of the membranes allow rapid heating and cooling for pulsed operations at high frequencies. The IR light sources are fabricated using MEMS technology.



Source Characteristics

- Wide spectral output
- Fast response
- High pulse rate
- High modulation depth
- High efficiency – low power consumption
- Long life and cost effective
- Custom design – many package options

Applications

- Infrared spectroscopy
- Explosive gas detection systems (hydrocarbon gases)
- Combustion efficiency and emissions monitoring (CO, CO₂)
- Toxic emission systems (SO_x, NO_x, NH₃)
- Air quality and environmental monitoring
- HVAC efficiency; controlling airflow by measuring CO₂ concentration
- Patient bedside monitoring systems
- Anesthesia gas monitoring systems
- Noninvasive glucose measurements
- Automotive engine control and exhaust monitoring



Electro Optical Components, Inc.

5460 Skylane Boulevard, Santa Rosa, CA 95403
Phone: (707) 568-1642 • FAX: (707) 568-1652
www.eoc-inc.com



Specifications

All parameters measured at 10 Hz, 50% duty cycle open to air, at room temperature and atmospheric pressure. For other frequencies, parameters may vary. Packaging in TO-5 or TO-39. The IR emitters can be supplied with CaF_2 , BaF_2 , ZnSe , Sapphire or Si windows.

Parameter	Typical	
Spectral Output Range	1.0 – 20 μm	See graph below
Emitter Surface Area	1.7x1.7 mm^2	Custom sizes available
Emitter Thickness	2 microns	Very low thermal mass
Resistance	50 Ω	45-55 Ω
Drive Voltage (pulsed, bi-polar or DC)	6.5 V	6-7 V
Drive Current	135 mA	130 – 140 mA
Working Temperature	750 $^\circ\text{C}$	
Modulation frequency	0 – 100 Hz	See graph below
Maximum Frequency at 50% Modulation	100 Hz	
Power Consumption	900 mW	850 - 950 mW
Integrated Power Emission	90 mW	80 – 100 mW
Warm-up Time	<30 msec	
Decay time	<5 msec	
Lifetime	>5,000 hours at 750 $^\circ\text{C}$ >25,000 hours at 600 $^\circ\text{C}$ >100,000 hours at 500 $^\circ\text{C}$	

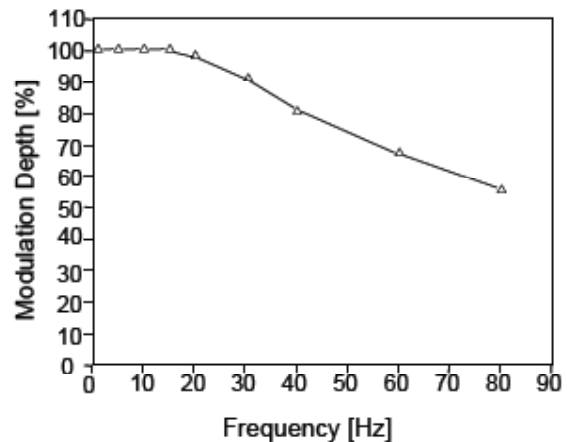
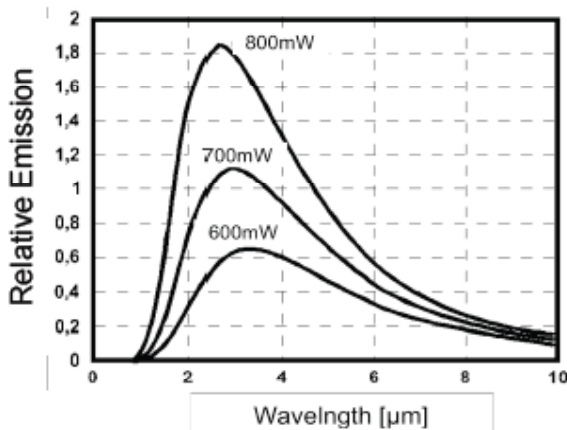

Electro Optical Components, Inc.



5460 Skylane Boulevard, Santa Rosa, CA 95403

Phone: (707) 568-1642 • FAX: (707) 568-1652

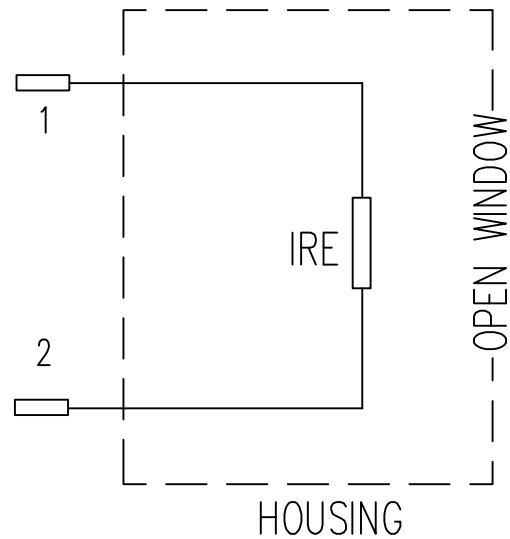
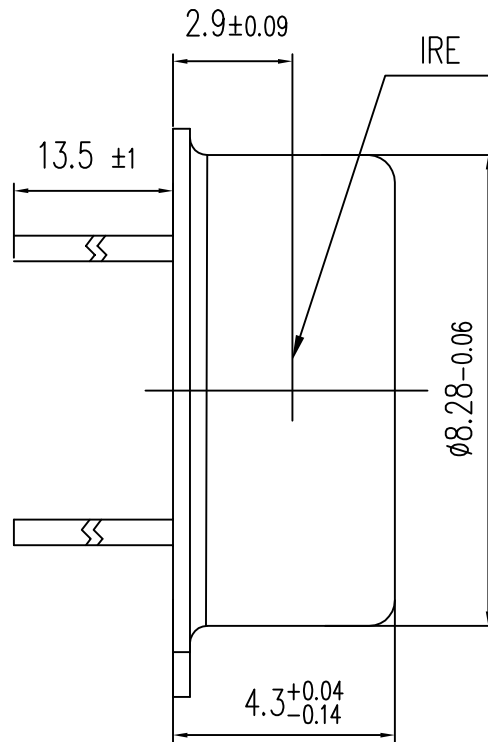
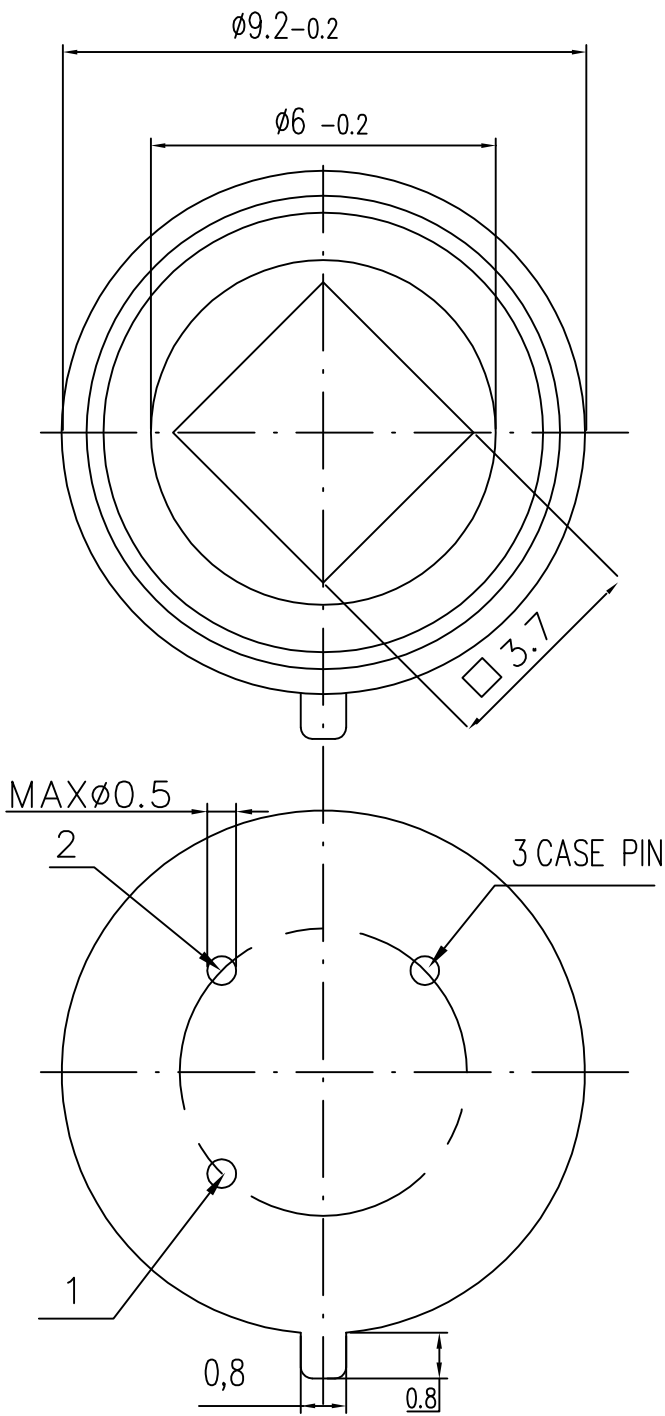
www.eoc-inc.com



BOTTOM VIEW

				GENERAL TOLERANCES		EDGES OF WORKING-PARTS ACC. DIN 6784	GEOMETRICAL TOLERANCES
				DATE	NAME	MATERIAL	
			DRAWN BY	19.02.07	Demchenko		
			CHECKED BY	19.02.07	Kirpilenko		
			SCALE	TITLE			DRAWING NO.
			5:1	ELEMENT ORIENTATION AND CONNECTIONS MIRL 17-900			520/476.201
							REPLACED BY
NO.	REVISION	DATE	NAME				

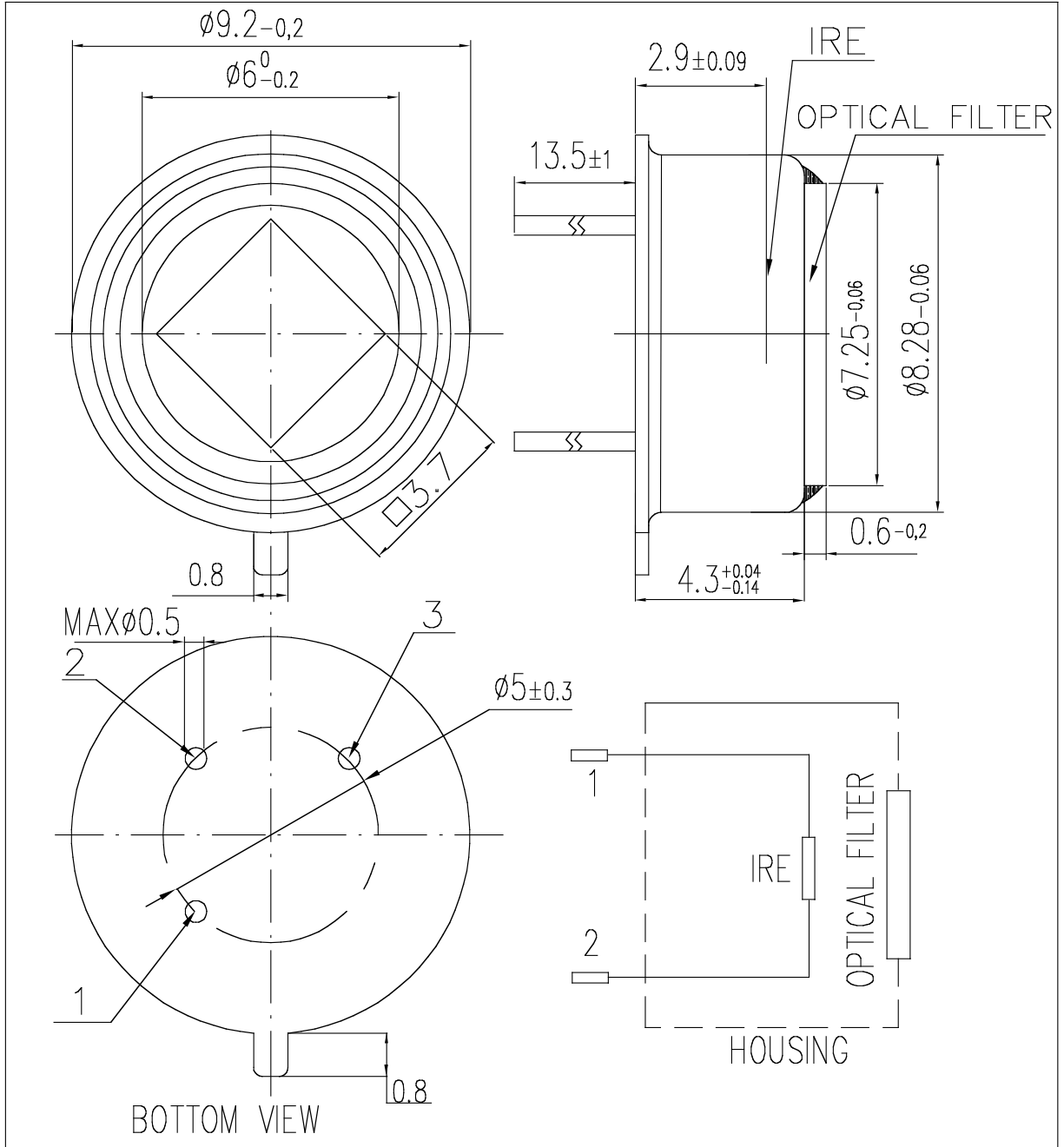

				GENERAL TOLERANCES		EDGES OF WORKING-PARTS ACC. DIN 6784	GEOMETRICAL TOLERANCES
				DATE	NAME	MATERIAL	
			DRAWN BY	19.02.07	Demchenko		
			CHECKED BY	19.02.07	Kirpilenko		
			SCALE	TITLE			DRAWING NO.
			5:1	ELEMENT ORIENTATION AND CONNECTIONS			520/476.202
				MIRL 17-900			REPLACEMENT FOR
							REPLACED BY
NO.	REVISION	DATE	NAME				