

Application Note 002/09 technical description of JSIR450

The JSIR450 is a wide band and powerful Infrared-Source. It has a big radiation power in the IR-band up to 15µm. In contrast to glow spiral emitters a circular homogeneous temperature distribution is reached. The JSIR450 has a broad spectral range output with high intensity. A high electric power consumption is possible within long lifetime. The JSIR450 works e.g. in infrared spectroscopy, gas detection systems, air quality and environment monitoring and in medical gas monitoring.

Index	Page
Technical Data	1
Order Information	1
Variations and Accessories:	2
• JSIR450 with TO39 Cap	2
• JSIR450 with Reflector	2
• JSIR450 Add on Reflector	2
• Emittance	3
• Intensity normalized vs. Angle	3
Additional information about the JSIR450	4
• Frequency-response: (Modulation Depth vs. Frequency)	4
• Temperature	5
• Emmission Spectrum vs. Wavellength	5
• Heating Area-/Case-Temperature	5
• Temperature Distribution of Heating Area	5

Type	JSIR450	
Spectral Output Range	typ 0.8 ... 15	µm
Active Area	3,8	mm ²
Resistant	12 (11 ... 13)	Ω
Critical Modulation Frequency	0,3 (0,25 ... 0,4)	Hz
Power Consumption	0,7	W
Operation Voltage	2,9	V
Operation Current	240	mA
Area Temperature	650	°C
Case Temperature at Air	106	°C
Operation Temperature	-40 ... +80	°C
Mass	2	G
Housing	TO5 modified	

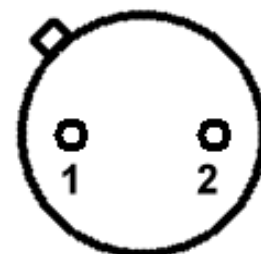

Connection:
Pin 1 Power
Pin 2 GND

Absolute Max. Ratings	Value	Unit
Voltage	4,5	V
Current	375	mA
Power	1,7	W

Order information: JSIR450 6350.01-3.01

Variations and Accessories:

The JSIR450 is offered in two versions. With a TO39 cap as a handling protection or with a parabolic reflector cap. In addition, a puttable on cap reflector can be ordered for the TO39 cap. The ray density could be raised by using a reflector around the 6-fold.

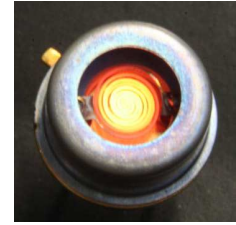

JSIR450 with TO39 Cap

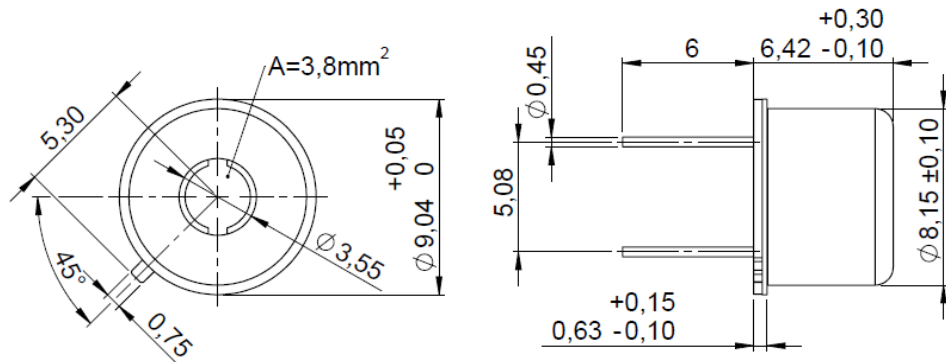
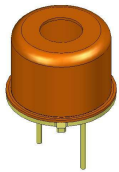

JSIR450 with Reflector

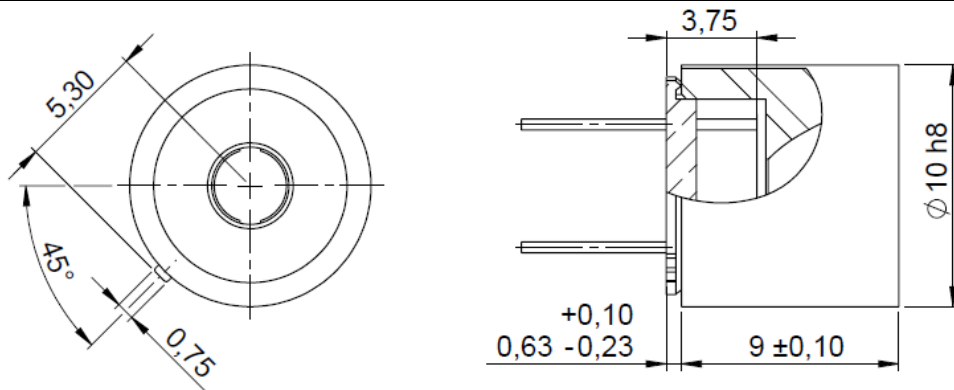
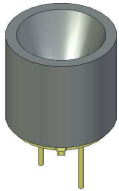

Add on Reflector

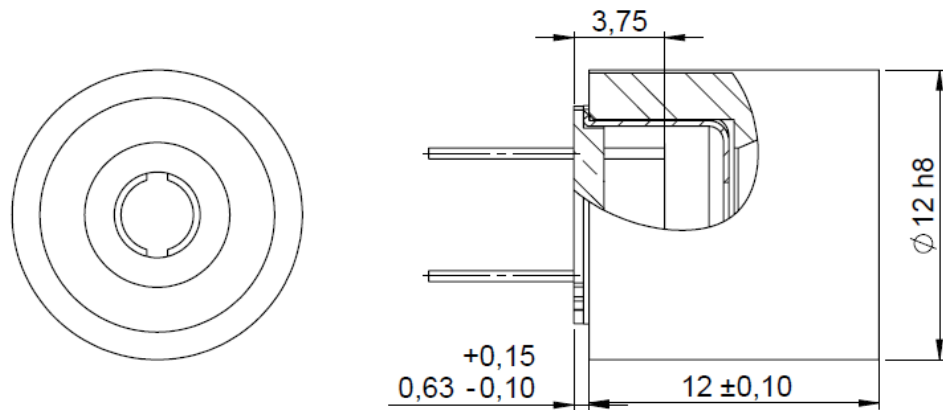
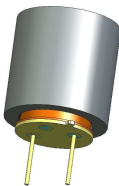

Radiant Intensity JSIR450 with TO39 Cap

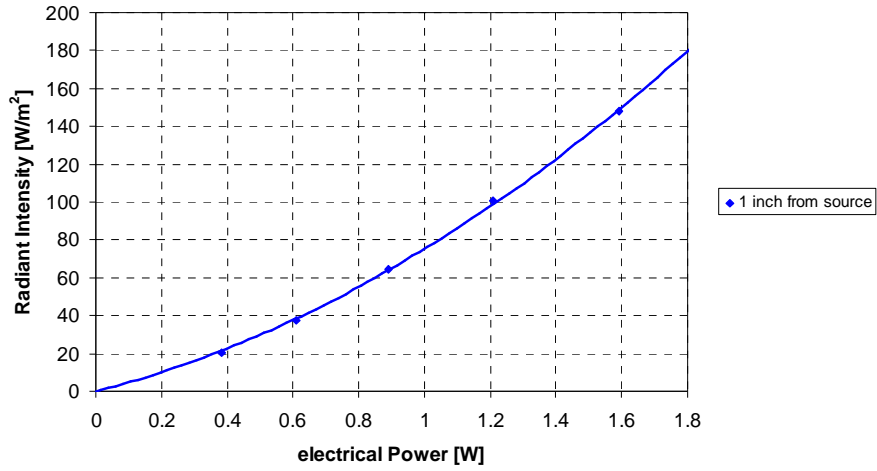

You can increase the radiant intensity by using a Reflector

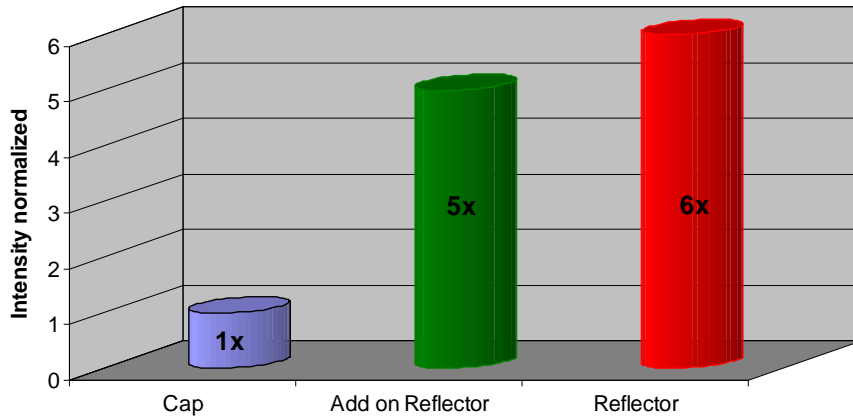

Intensity normalized vs. Angle

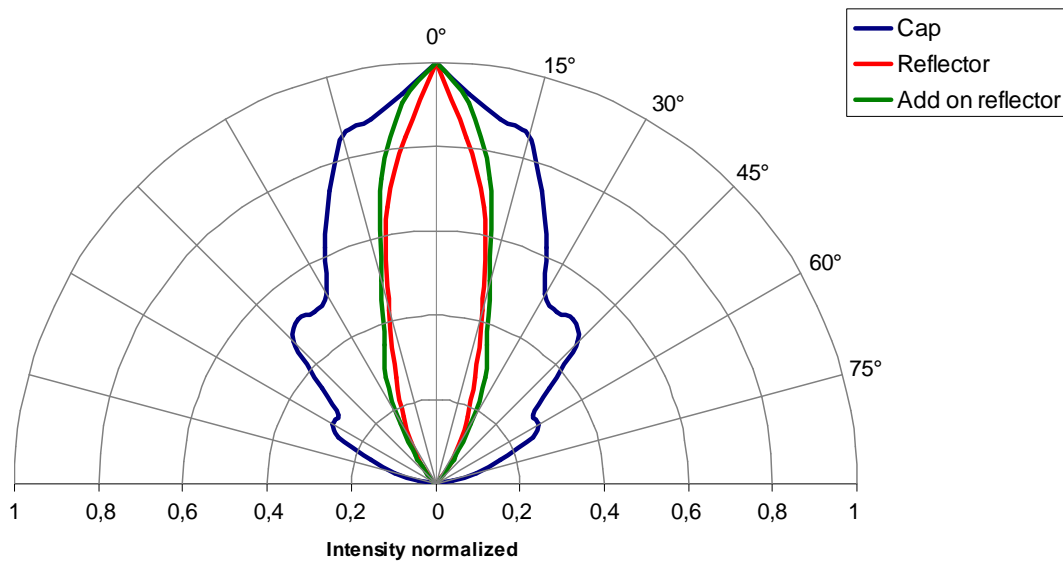

Additional information about the JSIR450

Frequency-responce: Modulation Depth vs. Frequency

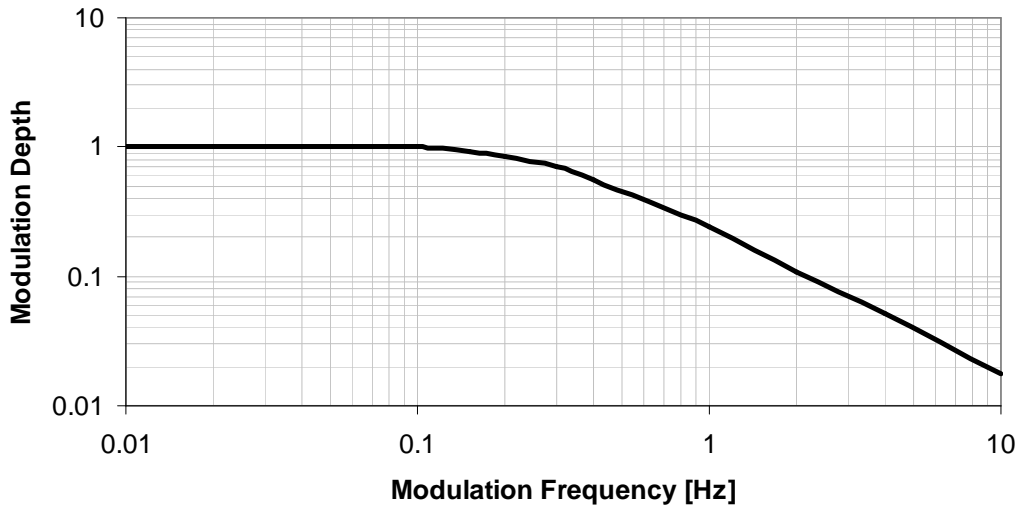

Temperature

The JSIR450 has the typical spectrum of a black emitter. The spectral intensity distribution depends on the temperature of the heating element which can be adjusted by the electric input power. A regular circular temperature distribution on the heating element is reached by special structuralisation.

Emission Spectrum vs. Wavelength

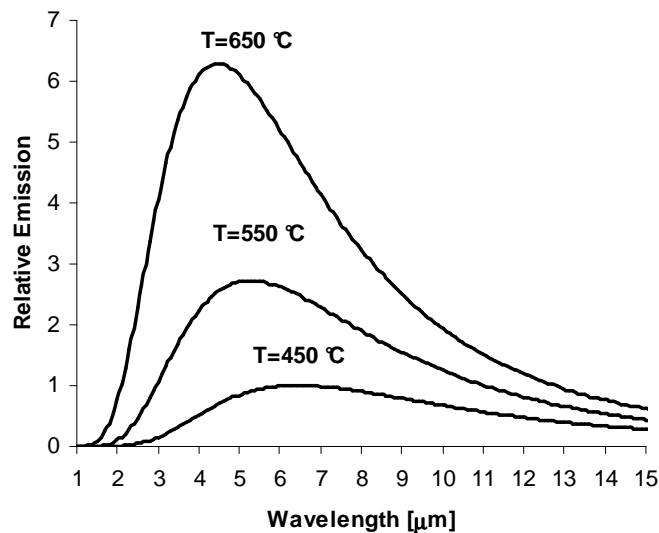

Heating Area- / Case-Temperature

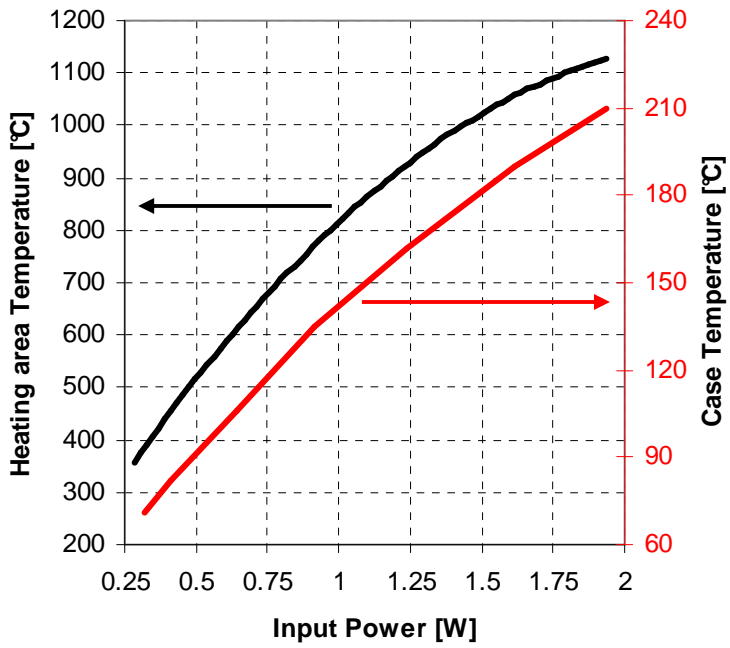

Temperature Distribution of Heating Area

