

## Pyroelectric Detectors

The product key of the pyroelectric detectors is defined in the following way:

Sensor Type (AA) Number of Channels (Bx) Chip type (C) Internal Circuit (DD) – Package (E) – Aperture (FFF) – Filling Gas (GG – Filters (H/H/H)

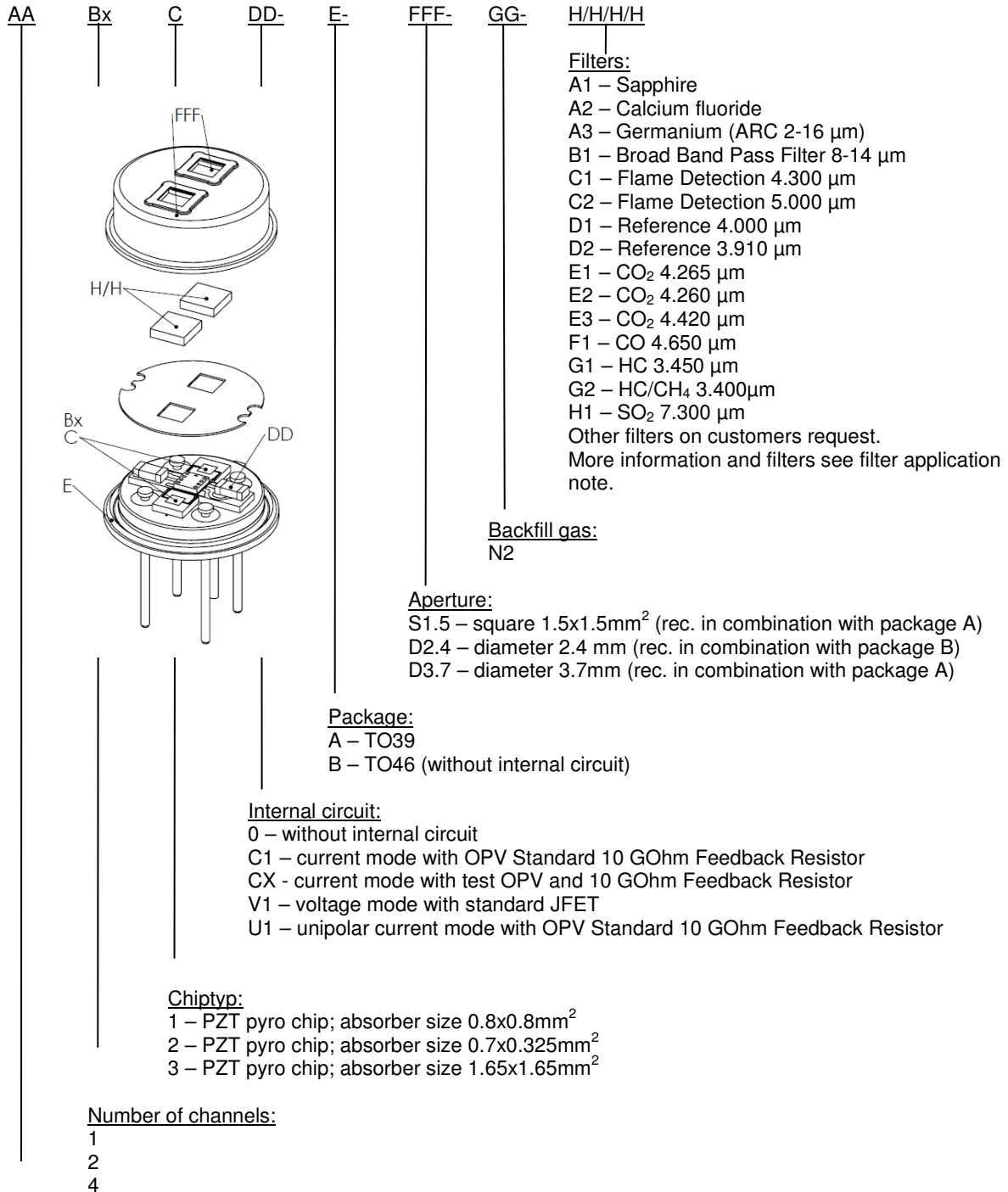

PS Pyroelectric sensor

e.g.: **PS2x1C1-A-S1.5-N2-A1/B1**