

One Channel Thermopile Detector TS1x80B-A-D0.48

Thermopile Detector based on thin film technology with a small active area recommended for temperature measurements with a band pass filter.

Active Area	∅ 0.5	mm
Aperture	∅ 0.5	mm
Number of Thermocouples per Channel	80	
Time Constant $t_{(0-63\%)}^1$	typ. 40	ms
DC Output Voltage ¹	typ. 2.2	mV
DC Sensitivity ¹	typ. 295	V/W
Temperature Coefficient of Sensitivity ²	typ. -0.4	%/K
Noise Voltage ³	typ. 18	nV/Hz ^{1/2}
Noise Equivalent Power NEP ¹	typ. 0.06	nW/Hz ^{1/2}
Specific Detectivity D* ¹	typ. 7.2×10^8	cmHz ^{1/2} /W
Resistance of Thermopile ³	20 ± 8	k Ω
Temperature Coefficient of Resistance ²	typ. -0.03	%/K
Thermistor	1 – PTC 1 k Ω m 2 – NTC 30 k Ω m 3 – NTC 100 k Ω m Technical specifications see document thermistors.	
Filling Gas ⁴	N ₂ / Kr	
Filters	Micro-Hybrid standard band pass filters and more information please see document "standard filters". Customized filters possible on request.	
Operation Temperature	-20 ... +85	°C
Mass	1	g
Housing	T039 (modified)	

¹ on air without windows, Blackbody T=500 K; E=38 W/m²

² temperature range from +25 to +70°C

³ at T_{amb}=25 °C

⁴ In case of Kr-filling increase of DC Output Voltage, DC Sensitivity, Specific Detectivity and Time Constant by the factor 1.8. Decrease of NEP by the same factor. Other gases on customer's request.



Bottom View

Pin Assignment:

- Pin 1 Output TP+
- Pin 2 Output TP-
- Pin 3 Thermistor
- Pin 4 Mass (GND)

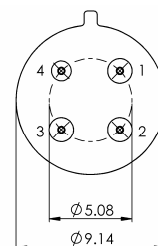

Ordering Information:

TS1x80B-A-D0.48 – Thermistor (F) –
Backfill Gas (GG) – Filter (H)

e.g. TS1x80B-A-D0.48-1-Kr-B1

Micro-Hybrid Electronic GmbH

Heinrich-Hertz-Straße 8
D-07629 Hermsdorf

Tel +49 366 01 592 100
Fax +49 366 01 592 110

Email: infrared@micro-hybrid.de
Web: www.micro-hybrid.de

One Channel Thermopile Detector TS1x80B-A-D0.48

Housing
T039 package

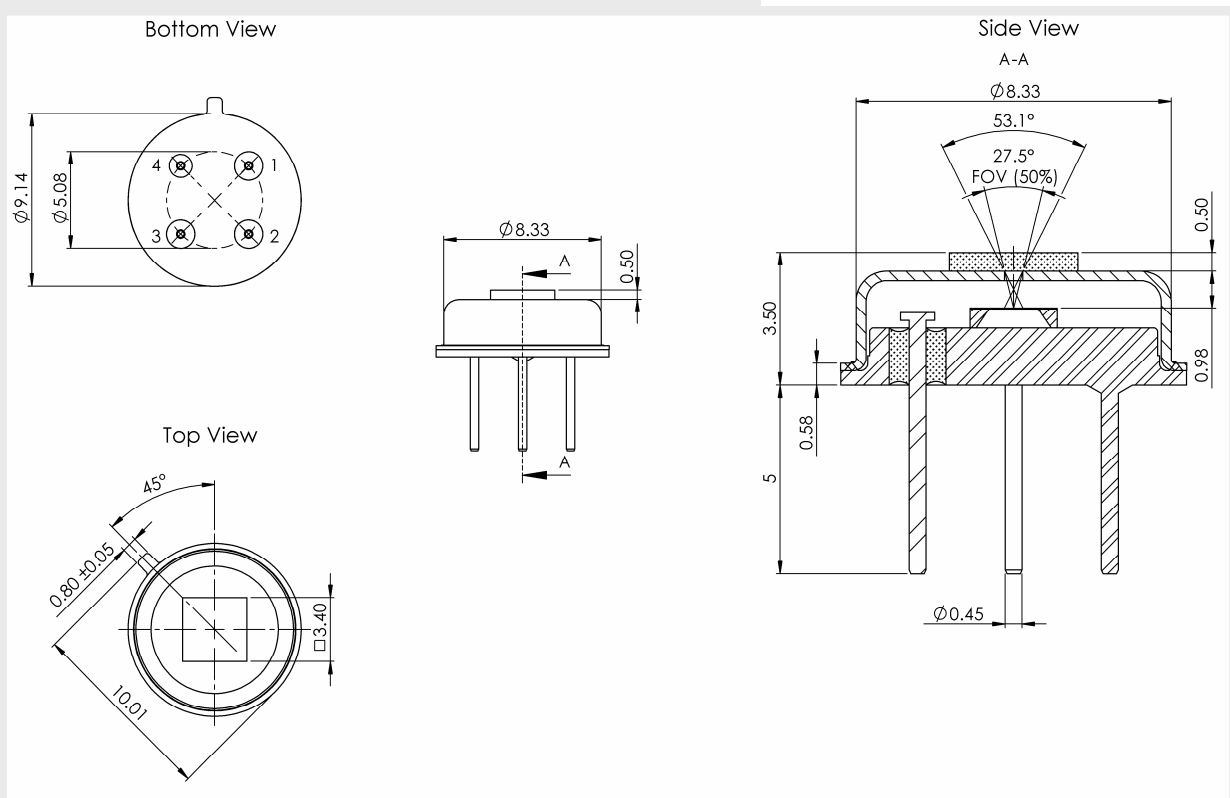

Optional parts:

IR-Source JSIR 350 - Fast IR emitter based on thin film technology
Art.-Nr. 6351.01-3.01

IR-Source JSIR 450 - Broadband IR emitter high performance for
heavily absorbing media
Art.-Nr. 6350.01-3.01

Preamplifier TE2AMP1 - Low noise preamplifier for Dual and Single
Thermopile Detectors
Art.-Nr. 9627.01-4.51

Micro-Hybrid Electronic GmbH

*Heinrich-Hertz-Straße 8
D-07629 Hermsdorf*

*Tel +49 366 01 592 100
Fax +49 366 01 592 110*

*Email: infrared@micro-hybrid.de
Web: www.micro-hybrid.de*