

GIPO Series

High voltage pulse generator (block configuration)

Patented – Under licence from the French “Commissariat à l’Energie Atomique” (C.E.A.)

1 standard model

Vin : 24Vdc

Vout : from -500V to -5.5kV

Pulse rising edge : 2.5ns typically on a load of 2pF



The GIPO product is basically composed of an adjustable high voltage dc/dc converter and a high speed, high voltage switch. The stability of the high voltage power supply integrated in the module is very high (10ppm/°C). For stand-alone operation, the amplitude of the HV pulse is fitted with an integrated trimmer. For remote control operation, it is fitted with an external 0/10V analogue signal. HV pulses are triggered by an external trigger 0-15V signal that enters either by the SMA socket, or by the SUBD9 connector. The GIPO is able to switch 5.5kV in less than 3ns. Pulse width, voltage and repetition rates can be adjusted by the user. This equipment is fully qualified and has been tested by some of the most important players in the optical and photonics domain.

- output voltages to -5.5kV
- block configuration
- low profile and lightweight
- fast commutation : -5.5kV in <3ns
- adjustable pulse width from 200ns to 30µs
- negative polarity
- for capacitive loads
- local and distant operations
- protection against polarity inversion and shortcuts

Parameters	Specifications
Input voltage Vin	24Vdc ±2V, (Max. 30V) power 6W
Output voltage Vout	continuously adjustable from -500V to -5500V
Pulse rising edge	2.5ns typically on a load of 2pF
Output signal width	continuously variable from 200ns to 30µs
Jitter	<200ps
Repetition rate	up to 100Hz
Polarity	fixed negative
Pulse synchronisation	input signal for synchronization, type CMOS 15V on 50Ω
Output voltage setting	via external voltage source 0/+10V, accuracy ±0.2%, input impedance > 1MΩ or via an internal trimmer
Output voltage monitoring	DC analogue 0/+10V buffered output signal, advised maximum output current 5mA
Operating temperature	0°C to +40°C
Storage temperature	-10°C to +70°C
Safeguards	<ul style="list-style-type: none"> ▪ 24Vdc input protected against polarity inversion ▪ input for voltage setting is internally limited at 10V ▪ monitoring output is protected against shortcuts ▪ repetition rate is internally limited at 100Hz ▪ the 50Ω resistor on the synchronization accepts 15Vdc ▪ pulse output on BNC high voltage safety
Provided accessories	specific coaxial shielded cable for high voltage equipped on one end with a BNC plug of safety RADIALL R317-074.

Possible Applications
▪ Flash Lamps Triggers
▪ Intensified CCDs
▪ Laser Diodes Drivers
▪ Multi Channel Plates
▪ Pockel Cells Drivers

Package Configuration	
Insulation	fully potted in an epoxy resin
Case material	aluminium case
Dimensions LxHxW	105 x 80 x 36 mm
Line input, setting and monitoring	through male Sub-D 9
Pulse output connector	BNC high voltage safety RADIALL R317-580
Fixation	with six holes cast into the flanges

Functional diagram

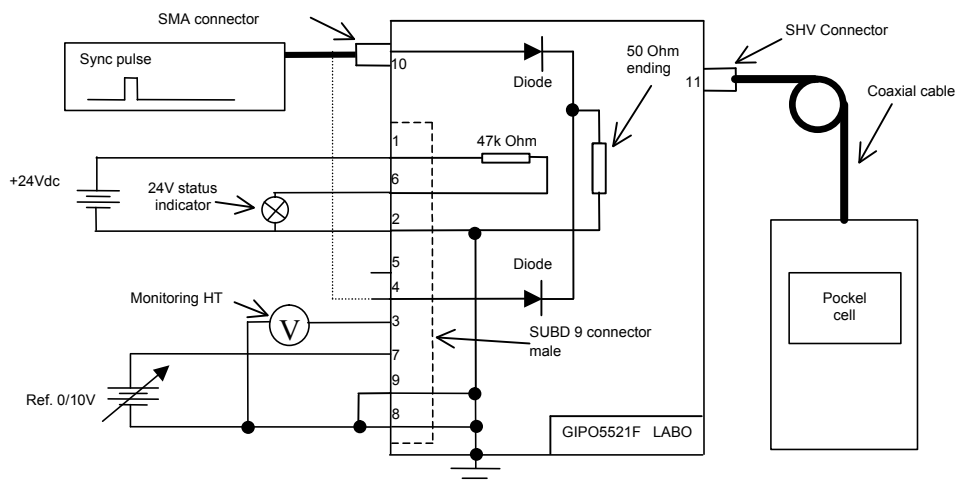

GIPO HIGH VOLTAGE SHORT PULSE GENERATOR: The new equipment improving your optical application

The basic architecture for High Voltage Pulse Generators (HVPG) is based on a high voltage source and a high voltage switch capable of connecting and disconnecting (short-circuit) at different frequencies the voltage source into a load. High voltage pulse generators are specifically designed to deliver a high amount of voltage (>100V) over a short period of time (<ns) into capacitive loads. They are typically used in applications requiring a repetitive source of high voltage pulses having fast rise and fall times. Switching time depends on the voltage required and on the technology used.

The Basic Technology of HVPGs

The core technologies of this type of equipment are divided into two parts. The first one which defines the technology used to store the high voltage, and a second one to release the stored energy to a load.

The energy is stored within electro-static fields (capacitors) or magnetic fields (inductor). Several types of technologies for the switch are available. The choice depends mainly on the voltage to switch, the repetition rate and the switching time. The most common are semi conductor technology, thyatron, krytron or spar-gap. The vast majority of today's high voltage pulse generators use capacitive energy storage system and semiconductor fast switching module. The improvement in the last decade on semiconductor technology makes it the perfect candidate to get superior performances and higher reliability.

By releasing the stored energy over a very short interval, a huge amount of peak power can be delivered to a load. The pulse-forming network is capable of generating a high-voltage pulse of up to 350kV which can be delivered in few nanoseconds.

Basically every system offers full control of the voltage, pulse duration, frequency and current limit, and can be connected to a computer to meet the most demanding industrial and research applications.

The Main Applications of HVPGs

High voltage pulse generators can be used in several applications including the optical and photonics domains where it is necessary to switch high voltage into a load during a short time. One of the main drawbacks of the majority of equipment remains the size. Today, thanks to the evolution and the miniaturization of technologies as semiconductor it is possible to achieve HVPG modules delivering more than 5kV in a package size of about 100 x 80 mm.

Main applications are:

- **Pockel Cells Drivers:** the cells based on electro-optic crystals are generally used in pulsed solid state lasers. Applying an electric field to an electro-optic material changes the refractive index. If the cell is placed between two crossed polarizers in the path of the laser beam, it is possible to block the light just by switching the electrical field applied to the crystal. Typically this application requires fast switching speed in the nanosecond range with high voltage from 3 to 10kV. Pockels cells are also used in pulse slicing or chopping, shaping and gating.
- **Multi Channel Plates** mainly used in laser induced fluorescence where it is necessary to increase the time resolution.
- **Intensified CCDs** used to visualise pulsed plasmas. This application is mainly done in research areas.
- **Laser Diodes Drivers.** High power laser diodes are used in several industrial processes where it is convenient to have a better quality process to drive them in pulsed mode.
- **Flash Lamps Triggers.** Flash lamps are mainly used for laser pumping. Xenon flash lamps are used in applications that do not require continuous illumination such as spectrophotometers, in-vitro diagnostics and factory automation.

SDS's HVPG : The GIPO

In its actual development, the GIPO is able to handle the above cited applications provided the devices, it is used with, match the GIPO specifications.

For the technical performances of the GIPO, please refer to the first page of this document.