

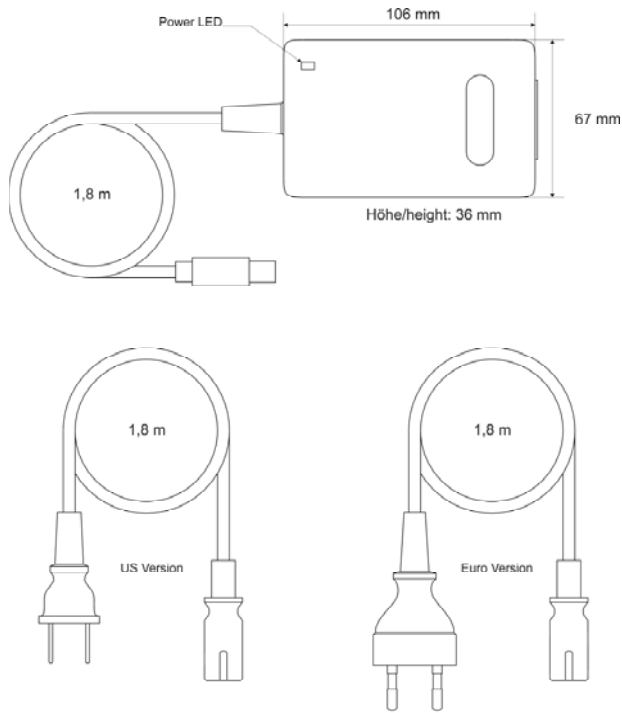

Datasheet	PS-15-25-L																																								
<h2>Power Supply for FEMTO Amplifier Modules</h2>																																									
Features	<ul style="list-style-type: none"> • Linear Regulated Stabilization ± 15 VDC • Low Ripple and Noise • Wide Input Range Switched Power Supply 																																								
Safety Instructions	<p>This power supply is exclusively designed for use with FEMTO amplifier modules. Before use, take care to follow general electrical safety rules and notice the information shown in this datasheet and at the type label on the power supply. Do not use visibly damaged power supplies. Do not use this power supply in security relevant applications or in chemical aggressive environment. Do not expose this power supply to unusual mechanical stress or vibrations. During use do not expose the unit to direct sunlight and do not cover it because cooling is made by convection. Respect the general rules for fire prevention. Use in original condition only, do not open, do not repair the unit. When operation is no longer possible or considered to be unsafe, the power supply must be taken out of service and be secured against unintended operation.</p>																																								
Environmental Protection	<p>FEMTO offers all end users in the EC the possibility to return "end of life" units without incurring disposal charges. If you wish to return a unit for waste recovery, please contact FEMTO for further information. Do not dispose of the unit in a litter bin or at a public waste disposal site.</p>																																								
Safety and EMI Requirements	<p>The manufacturer declares that this product meets the requirements and the intents of the following standards, normative documents and directives. The unit has (bears) the CE mark. A complete declaration of CE-conformity is available upon request.</p> <p>EN 55022 Klasse B, EN55024, EN 61000-3-2, EN 61000-3-3, EN60950-1, IEC 950 IEC 6100-4-2, IEC 6100-4-3, IEC 6100-4-4, IEC 6100-4-5 IEC 6100-4-6, UL1950 IEC 6100-4-11 RoHS 2011/65 EMV-Richtlinie 2004/108/EG, Niederspannungsrichtlinie 200/95/EG REACH Verordnung (EG) / Nr. 1907/2006</p>																																								
Specifications	<table border="0" style="width: 100%;"> <tr> <td></td> <td style="text-align: center;"><i>Test Conditions</i></td> <td style="text-align: center;"><i>T_a = 25°C</i></td> </tr> <tr> <td>Input</td> <td>Input Voltage</td> <td>100...240 VAC, $\pm 10\%$, 47...63 Hz</td> </tr> <tr> <td></td> <td>Power Consumption, no load</td> <td>2.3 W typ.</td> </tr> <tr> <td></td> <td>Power Consumption, max. load</td> <td>20 W max</td> </tr> <tr> <td></td> <td>Inrush current</td> <td>max. 15 A @115VAC max. 30 A @230 VAC.</td> </tr> <tr> <td>Output</td> <td>Output Voltage</td> <td>± 15 VDC, $\pm 5\%$ + 5 VDC (not connected to the output connector)</td> </tr> <tr> <td></td> <td>Output Current</td> <td>+ 500 mA / - 300 mA max.</td> </tr> <tr> <td></td> <td>Ripple and Noise</td> <td>20 mV_{pp} typ. (@ ± 150 mA load)</td> </tr> <tr> <td>Protections</td> <td>Insulation Voltage, prim./sec.</td> <td>4242 VDC</td> </tr> <tr> <td></td> <td>Insulation Resistance, prim./sec.</td> <td>10 GΩ min. (@ 500 VDC)</td> </tr> <tr> <td></td> <td>Temperature Protection</td> <td>installed</td> </tr> <tr> <td></td> <td>Overload Protection</td> <td>short-circuit-proof</td> </tr> <tr> <td></td> <td>No Load Protection</td> <td>idle-running-proof</td> </tr> </table>			<i>Test Conditions</i>	<i>T_a = 25°C</i>	Input	Input Voltage	100...240 VAC, $\pm 10\%$, 47...63 Hz		Power Consumption, no load	2.3 W typ.		Power Consumption, max. load	20 W max		Inrush current	max. 15 A @115VAC max. 30 A @230 VAC.	Output	Output Voltage	± 15 VDC, $\pm 5\%$ + 5 VDC (not connected to the output connector)		Output Current	+ 500 mA / - 300 mA max.		Ripple and Noise	20 mV _{pp} typ. (@ ± 150 mA load)	Protections	Insulation Voltage, prim./sec.	4242 VDC		Insulation Resistance, prim./sec.	10 G Ω min. (@ 500 VDC)		Temperature Protection	installed		Overload Protection	short-circuit-proof		No Load Protection	idle-running-proof
	<i>Test Conditions</i>	<i>T_a = 25°C</i>																																							
Input	Input Voltage	100...240 VAC, $\pm 10\%$, 47...63 Hz																																							
	Power Consumption, no load	2.3 W typ.																																							
	Power Consumption, max. load	20 W max																																							
	Inrush current	max. 15 A @115VAC max. 30 A @230 VAC.																																							
Output	Output Voltage	± 15 VDC, $\pm 5\%$ + 5 VDC (not connected to the output connector)																																							
	Output Current	+ 500 mA / - 300 mA max.																																							
	Ripple and Noise	20 mV _{pp} typ. (@ ± 150 mA load)																																							
Protections	Insulation Voltage, prim./sec.	4242 VDC																																							
	Insulation Resistance, prim./sec.	10 G Ω min. (@ 500 VDC)																																							
	Temperature Protection	installed																																							
	Overload Protection	short-circuit-proof																																							
	No Load Protection	idle-running-proof																																							

<p>Case</p> <p>Ambient Conditions</p>	<p>Material Device Socket, Main Color</p> <p>Dimensions Weight</p> <p>Storage Temperature Operating Ambient Temperature Air Humidity</p> <p>plastic housing, screwed small power socket, IEC-60320-C8 black</p> <p>106 mm x 67 mm x 36 mm (L x W x H) ca. 485g (inclusive AC power cord)</p> <p>- 40 ... + 85 °C 0 ... + 40 °C 0 ... 95%</p>
<p>Connector / Cable</p>	<p>AC Input Cord EU-Version</p> <p>US-Version</p> <p>DC Output Cord DC Output Connector</p> <p>Connector Pin Assignment</p> <p>VDE, 2 x 0.75 mm², black Euro-Plug, Typ C, CEE 7/16 to connector Euro 8, IEC-60320-C7</p> <p>US-Plug, Typ A, NEMA 1-15 to connector Euro 8, IEC-60320-C7</p> <p>22AWG, black LEMO Series 1S, 3-pol Type: FFA.1S.303.CLAC52</p> 
<p>Dimensions</p>	 <p>Power LED</p> <p>106 mm</p> <p>67 mm</p> <p>1,8 m</p> <p>Höhe/height: 36 mm</p> <p>1,8 m</p> <p>US Version</p> <p>1,8 m</p> <p>Euro Version</p> <p>0201-PS-15-25-L_R1</p>
<p>Scope of Delivery</p>	<p>Power Supply, AC Power Cord, Datasheet, Transport Package</p>

Specifications are subject to change without notice. Information furnished herein is believed to be accurate and reliable. However, no responsibility is assumed by FEMTO Messtechnik GmbH for its use, nor for any infringement of patents or other rights granted by implication or otherwise under any patent rights of FEMTO Messtechnik GmbH. Product names mentioned may also be trademarks used here for identification purposes only.

© by FEMTO Messtechnik GmbH
Printed in Germany