



Diamond-ATR Polycrystalline Fiber probe

High Temperature Version

Specification

Part Number IR01616WPR

Rev. A

Diamond-ATR fiber probe is assembled with Mid Infra-red transmitting silver halogenide polycrystalline fibers. The Probe consists of a shaft with a diamond cone sealed in the tip. A liquid-tight silicone covered metal sleeve protects the fibers outside the shaft. All the metal conductive parts of the probe have a good contact to each other from the tip to SMA-connectors including the metal base of protective conduit. The thermocouple is for the control of fiber temperature during the work.

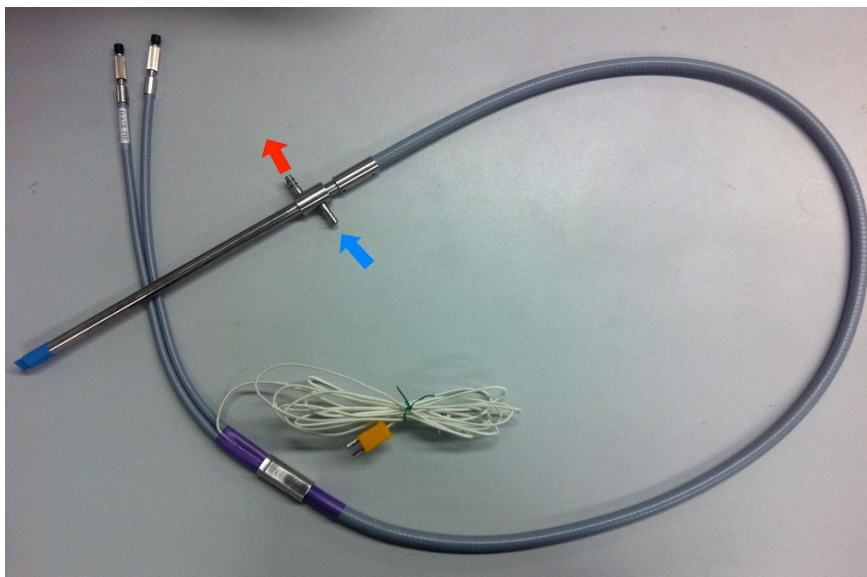
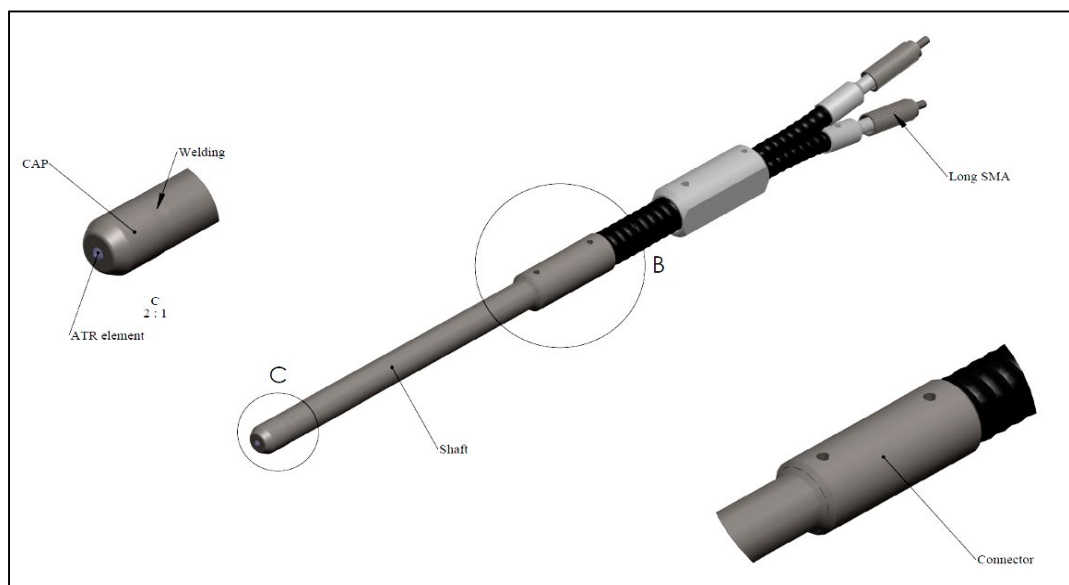

Addition for High-Temperature version of Diamond ATR probe: input and output of cooling gas should be connected as shown at the photo. The thermo junction position is approx. 12-15mm close to Diamond tip inside the shaft.

Working Parameters & Environmental Conditions

Reference	Parameter	Value	Verification Method
1.	Full Spectral range (1% of max. transmittance)	600 – 1900 cm ⁻¹	Test
2.	Transmission at 973 cm ⁻¹	> 7%	Test
3.	Transmission at 1850 cm ⁻¹	> 0.3%	Test
4.	Acetone peak height (1090cm ⁻¹ – 1020cm ⁻¹)	> 18%	Test
5.	Fringing	< 0.4%	Test
6.	Bending absorption peak	< 7%	Test
7.	Pressure	200 Bars	Test
8.	Temperature working range (continuous)	-150°C +250°C	Test
9.	Cooling gas excess pressure/gas consumption	1Bar/??	Design
10.	Minimal bending radius	130 mm	Design

Materials table - Diamond-ATR probe

Fibers material	<i>Silver chloride-silver bromide solid solution</i>
Fiber inner protective tubing	<i>PEEK</i>
ATR element	<i>Diamond III A</i>
Sealing between diamond and metal	<i>PEEK</i>
Probe tip and shaft material	<i>Hastelloy C-22</i>
Protective conduit material	<i>Stainless steel with silicone covering</i>
Connectors material (inside coupler)	<i>Stainless steel, brass, Titanium</i>

Please verify the chemical compatibility of Hastelloy C-22 with the chemicals in use and the operating temperature.

Handling Instructions

Handle Diamond-ATR Probe with care.



The probe contains silver halogenide fibers that are flexible but can be damaged following a shock on the probe shaft or the fibers protective sleeve. The bending radius of the fibers is limited to 15 cm, i.e. 30 cm diameter. Bending the probe over this limit may result in permanent transmission loss especially in spectral range of 3-8 microns ($1250\text{-}3333\text{ cm}^{-1}$).

- Do not bend the probe fiber to a diameter smaller than 30 cm.
- Operating temperature range is $-150^{\circ}\text{C}+250^{\circ}\text{C}$. Do not overheat the probe shaft! It results in the failure of Diamond cone sealing!
- Do not heat the probe shaft above 140°C without air/gas cooling. It results in permanent damage of the fibers.
- Continue the air/gas cooling after use at elevated temperature till the outer temperature decreases upto 140°C .
- Replace protective cap onto probe tip when not in use.
- Hold the probe at both ends when transporting.
- Prevent the drop of the probe when laying on a surface.
- Place the probe in the storage box when not used.



Despite being the hardest known material, diamond toughness ranges from fair to good compared to other engineering materials. Though the diamond crystal could hardly be scratched it might break upon a strong impact with another hard material. The diamond crystal protrudes from the tip, hence could take in all the impact.

Cleaning Instructions

The probe tip, including the diamond cone, can be cleaned using any solvent required. Isopropanol is the preferred rinsing solvent to minimize residues on the probe tip and shaft.

A soft brush can be used for manual cleaning. Use a lint-free napkin or dry air to dry the tip.

Visually inspect the probe shaft and tip – the diamond cone especially- for any residue left. Repeat the cleaning procedure until the probe appears clean. To make sure the cleaning is complete determine the optical cleanliness of the diamond crystal:

- Collect a reference spectrum.
- Clean the cone with appropriate solvent(s).
- Collect a Sample spectrum (transmission %) and look for bands within the system effective range. Sample spectrum should be a smooth 100% line if the probe tip is clean.

Storage Instructions

When the diamond ATR probe is not to be used for a relatively long time period, carefully remove the probe from the reactor. Make sure to follow all recommendations and warnings mentioned in this instruction, regarding shocks, bending and cleaning.

- Do not over bend the probe fiber.
- Put the caps onto the probe tip.
- Place the probe into its storage box and place the latter in a suitable location for a safe storage.