



Electro Optical Components, Inc.

5464 Skylane Boulevard, Suite D, Santa Rosa, CA 95403

Toll Free: 855-EOC-6300

www.eoc-inc.com | info@eoc-inc.com



MDS-5
EVALUATION SYSTEM FOR
METHANE DETECTION
INSTRUCTION MANUAL



rev. 100815

TABLE OF CONTENTS

General Information	3
Application	3
Packaging arrangement	3
Operation conditions	3
Brief Overview of the Components Included	4
Recommended operation mode for the system	5
Operating instructions	6-7
Precautions	8
Appendices	9
Appendix 1: Lms34LED-CG main parameters	9
Appendix 2: Lms36PD-05-CG main parameters	10
Appendix 3: Drivers Applicable for the MDS-5 Evaluation System	11
Appendix 4: MDS-5 testing results with different gas concentrations	12-13

GENERAL INFORMATION

Application

MDS-5 is an evaluation system for CH₄ detection based on mid-infrared LED-PD optopair. It is an out-of-the-box solution that can be launched with minimal effort and can provide fast results.

Packaging arrangement

MDS-5 includes:

- Optical cell that incorporates:
 - Light-emitting diode Lms34LED-CG
 - Photodiode Lms36PD-05-CG
- PD preamplifier
- D41/D51/ mD-1p LED Driver (depends on customer request)
- SDM Synchronous Detector

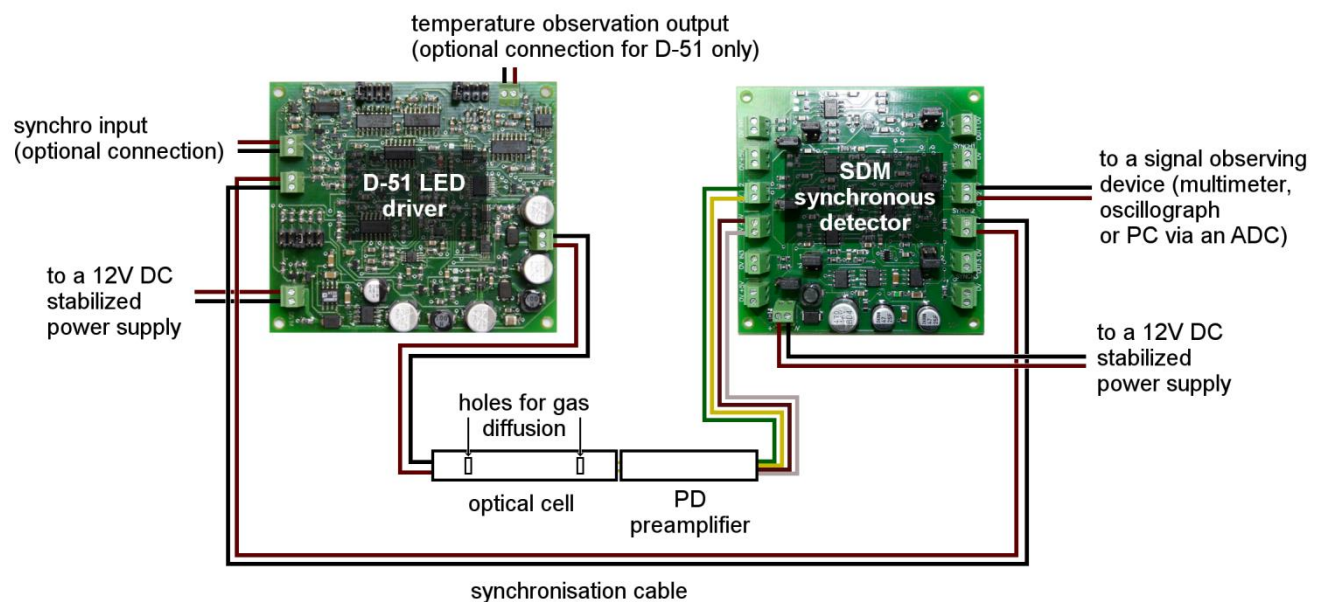

Operation conditions

Indoor operation only. Ingress Protection Rating IP00.

BRIEF OVERVIEW OF THE COMPONENTS INCLUDED

- Optical cell

The optical cell includes light-emitting diode Lms34LED-CG and photodiode Lms36PD-03-CG mounted inside the metal chamber.

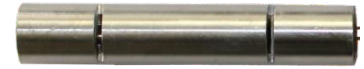

MDS-5 optical cell

Tube-type chamber is made of steel and is polished inside to assure minimal LED radiation loss through an optical path. There are two holes in the chamber for gas diffusion. The length of the chamber is about 50 mm, its diameter is 9 mm, and the length of the optical path is 30 mm.

Light-emitting diode Lms34LED-CG – LMSNT light-emitting diode with 3.4 μm peak wavelength covered with a special glass for increased output optical power. For detailed information and set of characteristics please refer to **Appendix 1**.

Photodiode Lms36PD-05-CG – LMSNT photodiode with 3.6 μm cut-off wavelength covered with a special glass for increased responsivity. For detailed information and set of characteristics please refer to **Appendix 2**.

- D41/D51/ mD-1p LED Driver (depends on customer request)

LED Driver is a power supply for Lms34LED-CG. D41/D51 driver types have a set of adjustable parameters to customise the desired operation mode of an LED. mD-1p driver provides operation at one fixed pulsed mode.



D51 LED Driver

For brief information about drivers, please refer to **Appendix 3**. For comprehensive information about drivers please refer to the Instruction Manual appropriate to your driver model.

- PD preamplifier in an aluminum tube

PD preamplifier amplifies the current, generated by photodiode, and converts it into voltage signal. There is straight correspondence between PD current and resulting output voltage, i.e. if the photocurrent from photodiode is a meander, the converted signal will be a meander too with the same frequency and pulse duration. The preamplifier is placed in aluminum tubing for noise reduction.

- SDM Synchronous Detector

SDM synchronous detector measures the voltage signal from the output of photodiode preamplifier and converts it to the DC voltage signal proportional to amplitude of voltage from input.

For comprehensive information about the synchronous detector please refer to the appropriate Instruction Manual.



SDM

Synchronous Detector

RECOMMENDED OPERATION MODE FOR THE SYSTEM

Driver settings (for D-41/D-51 driver types)		
Drive current	I, A	0.2-1
Pulse duration	τ , μs	10-20
Frequency	f, kHz	0,5
Synchronous detector SDM settings		
Signal gain	times	x5
Averaging time	ms	200

OPERATION INSTRUCTIONS

1. Connect the optical cell's photodiode with the preamplifier tube.

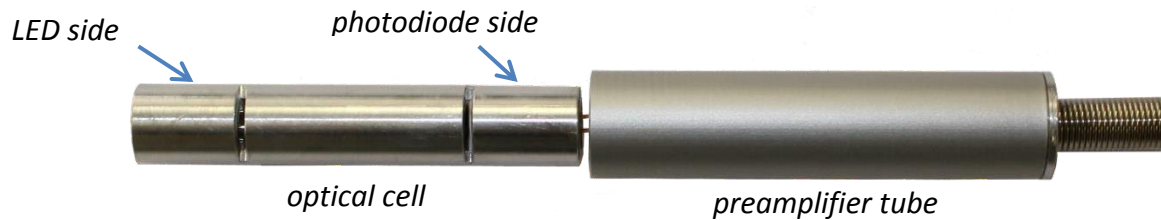

Note! Please observe the polarity of the connection. Photodiode anode (marked with red) must be connected to the “+” sign of the preamplifier socket.

2. Connect the preamplifier output with an input of SDM synchronous detector.

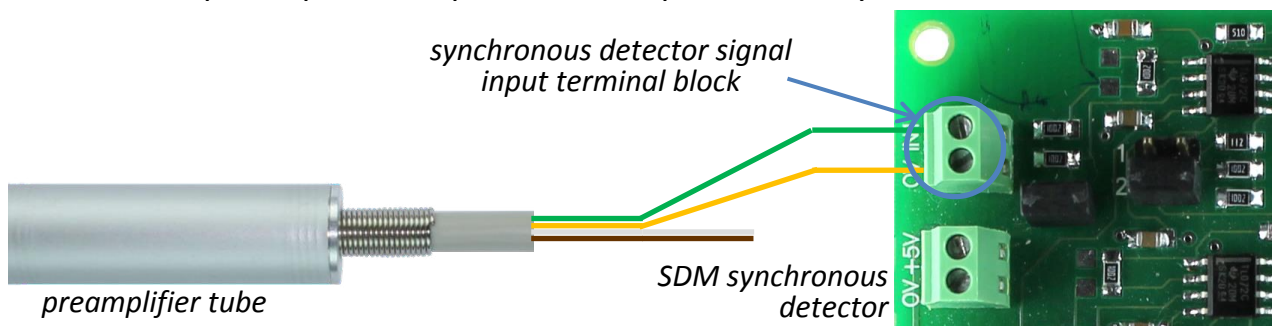

Green cord – to the signal input “+”; Yellow cord – to the signal input “0”

3. Connect a 5V power output of the SDM synchronous detector to the preamplifier power input.

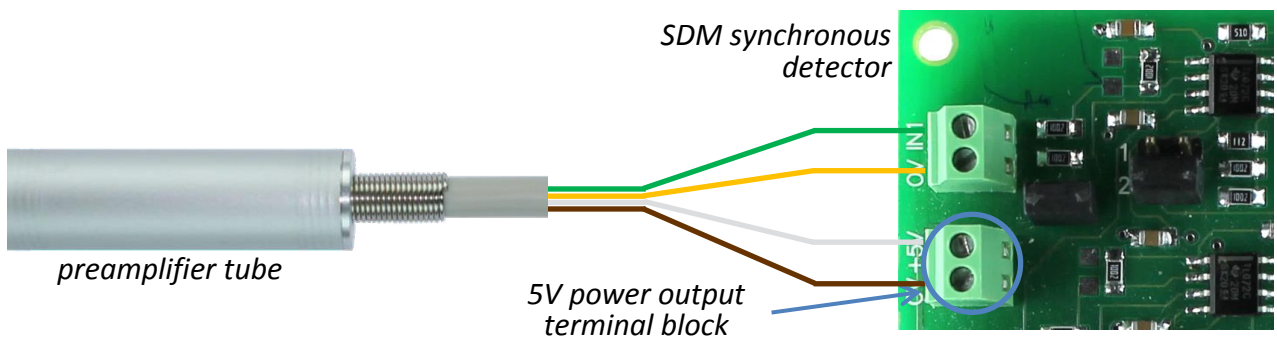

White cord – to the power output “+”; Brown cord – to the power output “0”

4. Connect gas chamber's LED with terminal block of LED driver.

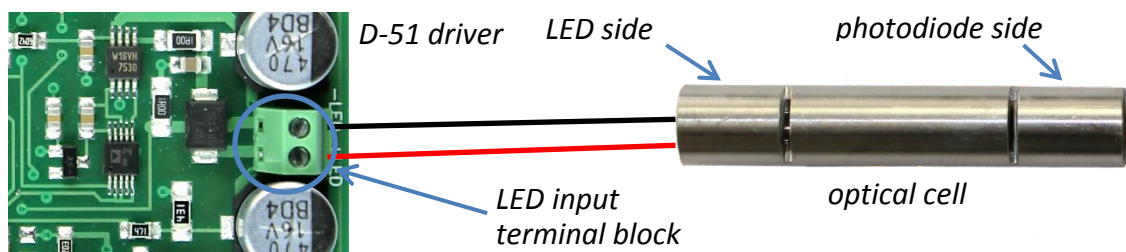

Note! Please observe the polarity of the connection. LED anode (marked with red) must be connected to the “+” sign of the driver socket.

OPERATION INSTRUCTIONS

- Connect the synchronisation output of the LED driver with the synchronization input of the synchronous detector via synchronization cable.

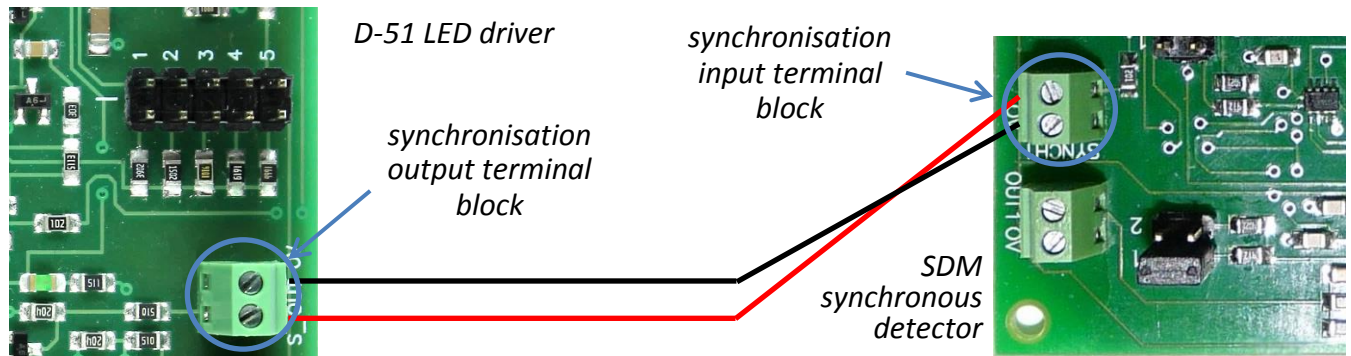

- Select the needed mode of the LED driver using pulse duration, frequency and current adjustment jumpers (available for D41/D51 driver types).
Note! You can find out more about driver modes and their adjustment in the appropriate driver Instruction Manual.
- Select the needed mode of the SDM synchronous detector using signal gain and averaging time adjustment jumpers.
Note! You can find out more about synchronous detector modes and their adjustment in the appropriate synchronous detector Instruction Manual.
- Connect signal output terminal block of SDM (U_{SIG}) and temperature observation output of D-51 (U_{TEMP}) with signal observing device (multimeter, oscilloscope or PC via ADC).

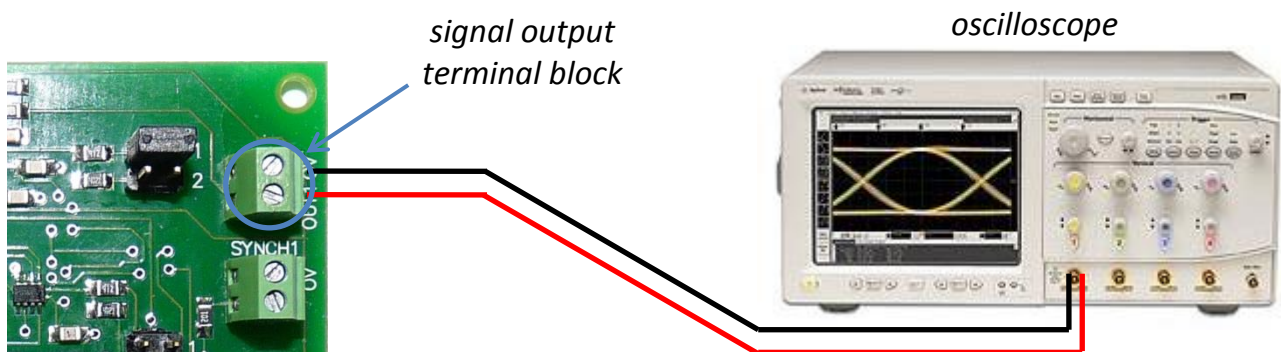

- Connect a 12V DC stabilized power supply to the LED driver and SDM synchronous detector. They will turn on.

PRECAUTIONS

- ⚠ Turn on the power supply of the LED Driver and SDM synchronous detector only after all connections are made and tested.
- ⚠ Do not switch driver regimes during operation.
- ⚠ Do not disassemble the optical cell; otherwise the optical system will be damaged.
- ⚠ Do not use multimeter to control and adjust current of the LED.

Note! Please refer to your provider if you have any questions.

APPENDIX 1

Lms34LED-CG Main Parameters (QCW operation mode, f=0.5 kHz, T=24°C)

Parameters	Units	Conditions	Ratings
Peak emission wavelength	μm	T=300 K, I = 150 mA qCW	3,30 — 3,49
FWHM of the emission band	nm	I = 150 mA qCW	250 — 600
Quasi-CW Optical Power	μW	I = 200 mA qCW	min 80
Pulsed Peak Optical Power	μW	I=1 A, f=1 kHz, duty cycle 0.1%	min 950
Voltage	V	T=300 K, I=200 mA	0,2 — 0,5
Operating temperature	°C	-	-25...+50
Package	TO-18 package with a conic reflector		

Spectra at 200 mA (qCW, duty cycle 50%, T=300 K)

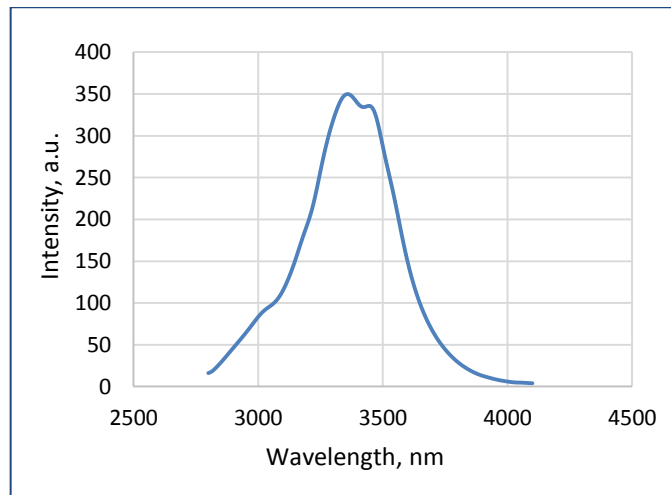

LED Typical Current-Voltage Characteristics (T=300K)

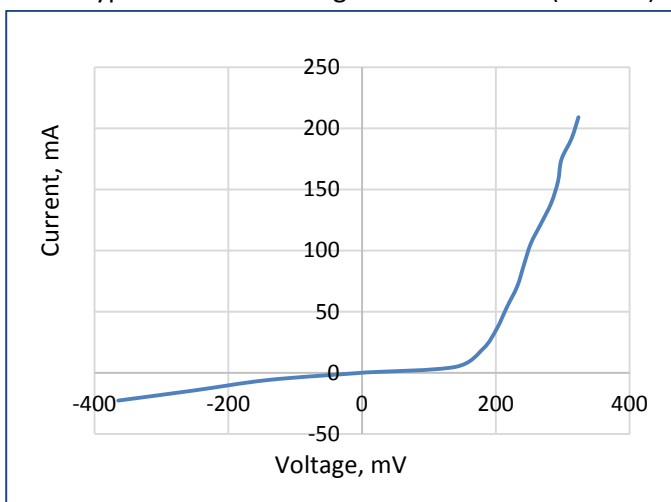

LED Power Characteristic (quasi-CW mode, T=300K)

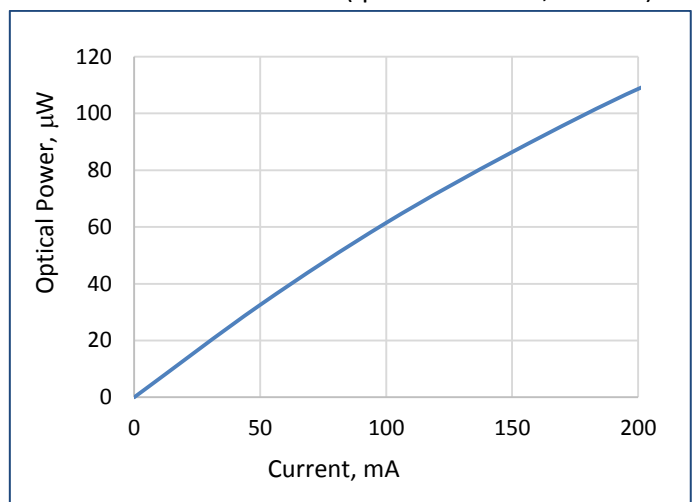

APPENDIX 2

Lms36PD-05-CG Main Parameters (T=24°C)

Parameters	Conditions	Symbol	Value	Units
Cut-off wavelength	T=300 K	λ_{cut}	3.6	mm
Max. sensitivity wavelength (>90%)	T=300 K	λ_p	2.2 — 3.4	mm
Dark current	T=300 K, $V_r = -0,1$ V	I_d	0.5 — 1	mA
Shunt resistance	T=300 K, $V_r = -10$ mV	R_{sh}	0.2 — 0.8	k Ω
Capacitance	T=300 K, $\lambda = \lambda_p$	C	600 — 1400	pF
Operating temperature	-	T_{opr}	-25...+50	°C
Package	TO18 with a conic reflector			

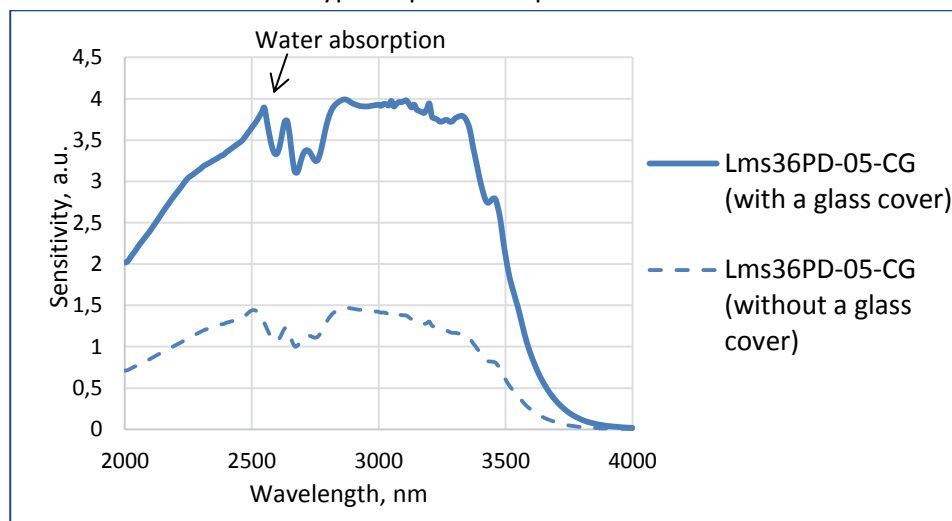

Typical spectral response

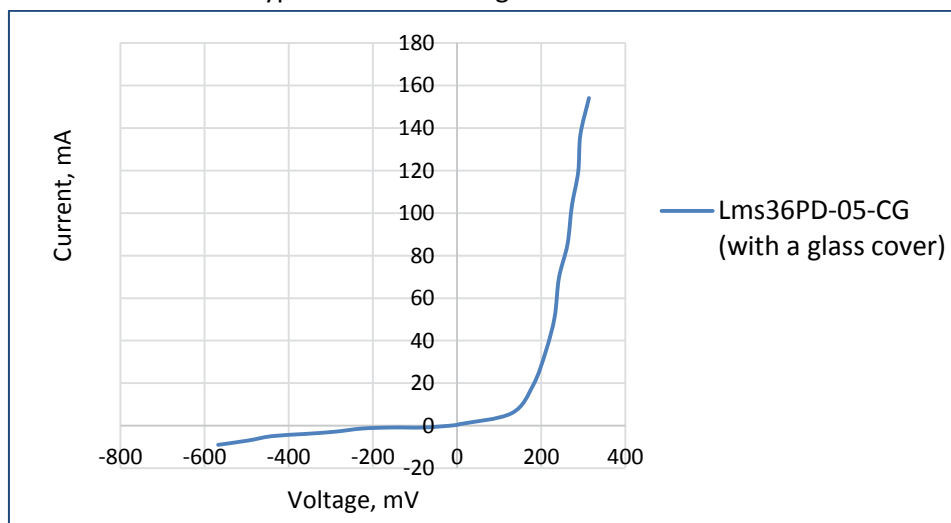

Typical current-voltage characteristic



Drivers Applicable for the MDS-5 Evaluation System

<p>LED driver D-41</p> 	<p>D-41 Driver provides Pulse mode operation. Using this mode it is possible to choose one of five current values (0.2, 0.6, 1, 1.5, 1.9 A) and select one of four frequencies (0.5, 2, 8 and 16 kHz) and choose pulse duration within four values (2, 5, 10 and 20 μs).</p>
<p>LED driver D-51</p> 	<p>D-51 Driver has the same characteristics as D-41 but also has another important feature:</p> <p>Temperature control – possibility to define LED p-n junction temperature using current-voltage dependence. Driver generates the low current signal for plugged LED, measures and outputs the voltage. Using the obtained voltage value it is possible to calculate the intrinsic LED temperature.</p>
<p>mD-1p minidriver</p> 	<p>mD-1p minidriver is a cost-effective driver that enables LED operation at fixed driving mode: 2 A current, 2 kHz frequency and 5 μs pulse duration.</p>

MDS-5 testing results with different gas concentrations

Gas mixture	Methane concentration, ppm	Signal Output, V	Standard Deviation, mV	Noise, mV	Resolution, ppm
Air (Dry Bottled)	0	7.84	0.76	2.28	-
CH ₄ + N ₂	1000	7.81			76
CH ₄ + N ₂	2500	7.76			71
CH ₄ + N ₂	5000	7.69			76
CH ₄ + N ₂	10000	7.59			91
CH ₄ + N ₂	50000	7.24			190

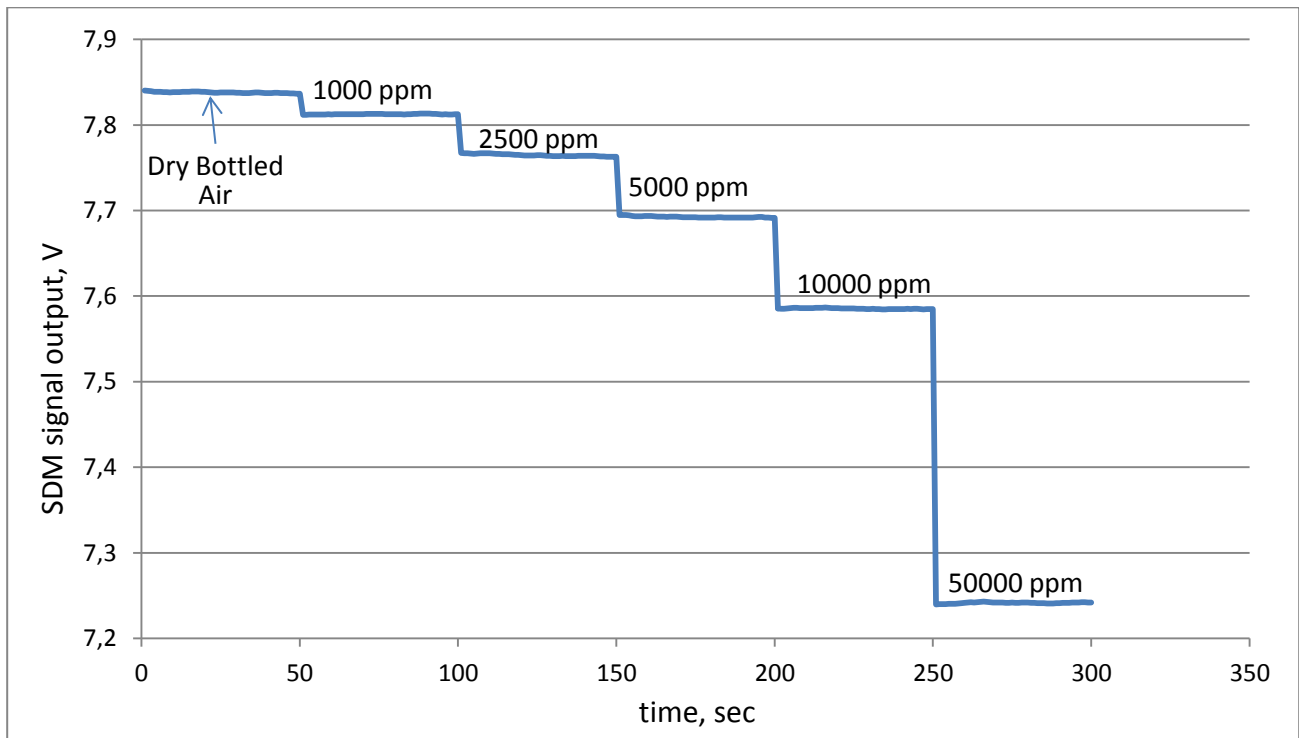

APPENDIX 4

Relative signal change dependence on methane concentration
 (measured at SDM signal output)

$$U_{AMPL} = \frac{U(C) - U(C_0)}{U(C_0)}$$

