



TECHNICAL NOTE



Driver Circuit Recommendations for EOC-IRE Series

Our infrared (IR) emitters are powerful and high-efficient IR radiation sources that meet the demands for reliable and high-precision gas sensors and offer a wide range of application scenarios in IR spectroscopy. Our IR emitters are characterized by a very low temperature coefficient of electrical resistance. Therefore the hot resistance and the cold resistance are almost identical which eases the electrical control of the IR sources.

All IR sources can be driven in electrical voltage, current or power regulated mode. The application decides whether the operating mode is DC or AC (pulsed). Depending on the drive mode and the applied electrical power the electrical resistance of the IR emitter can change over time. For highest measurement accuracy a power regulated mode is always recommended for thermal IR emitters. However, it is the most complex operating mode and not suitable in all applications.

For applications that require a small and low-cost driving circuit with a maximum stability close to a power regulated mode a simple circuit with an adjustable low dropout voltage (LDO) regulator is proposed (Fig. 1). The LDO regulator is a linear voltage regulator that regulates the drive voltage of the IR emitter even when the supply voltage is very close to the output voltage. This enables a wide range of input voltage and is also of advantage in battery-powered applications. A single external resistor R3 is used to set a current limit and, hence, a power limit. If the circuit is correctly dimensioned and adjusted in its operating point to the electrical resistance of the IR emitter, the electrical drive power remains constant for small resistance changes and over a wide input voltage and temperature range.

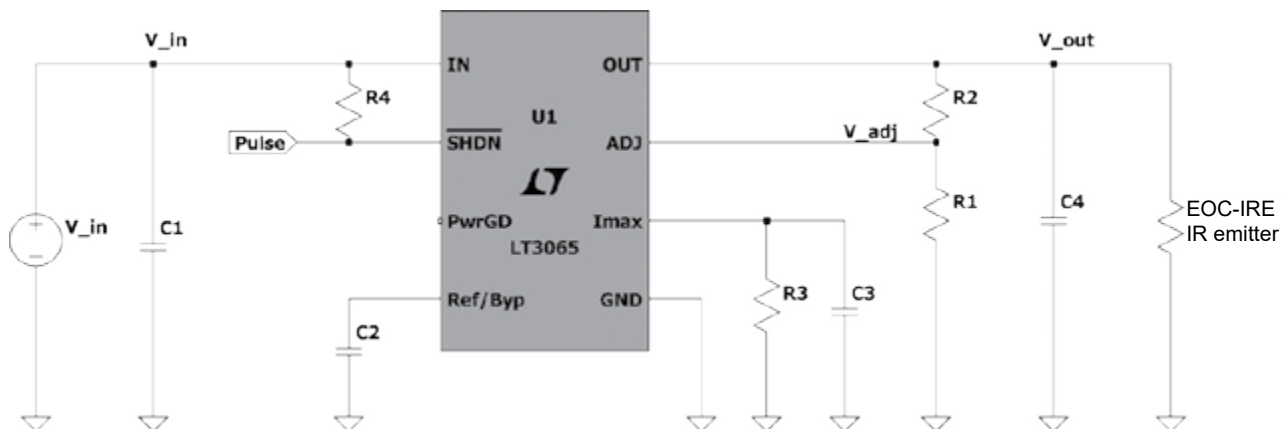

Fig 1: Application circuit to drive EOC-IRE series IR emitters with the LDO regulator LT3065

Set of parameters for maximum operating power

Part	EOC-IRE Series	
	EOC-IRE-550R & -C	EOC-IRE-550R-SAP
R_{Emitter}	22.6 Ω	22.6 Ω
R1	11 k Ω	11.8 k Ω
R2	61.9 k Ω	61.9 k Ω
R3	1.69 k Ω	1.78 k Ω
R4	510 k Ω	510 k Ω
C1	3.3 μF	3.3 μF
C2	10 nF	10 nF
C3	22 nF	22 nF
C4	3.3 μF	3.3 μF
LDO regulator U1	LT3065	
Input voltage (V_{in})	(4.3 ... 10) V	
Pulse signal voltage	Low/OFF: (0 ... 1) V High/ON: 1.5 V ... V_{in}	
Drive power	700 mW	630 mW

Table 1: Set of parameters to drive EOC-IRE series IR emitters at its maximum operating power.

The drive power P of the IR emitter is set with the resistors $R1$, $R2$ and $R3$. For correct dimensioning, the following equations must be used to calculate the required resistance values for a given drive power P and a given electrical (hot) resistance R_{Emitter} of the IR emitter:

$$R1 = (8 \dots 62) \text{ k}\Omega$$

$$R2 = R1 * \left(\frac{\sqrt{P * R_{\text{Emitter}}}}{0.6 \text{ V}} - 1 \right)$$

$$R3 = \frac{300 \text{ V}}{\sqrt{\frac{P}{R_{\text{Emitter}}}}}$$

It is recommended to use resistors with 1 % tolerance or less (E96 or E192 series) to set the drive power. This keeps drift to a minimum and achieves maximum stable operation. All other parameters are kept constant as given in Table 1. For DC mode operation the pulse signal voltage has to be set to HIGH state or input voltage V_{in} .

Driving circuit board

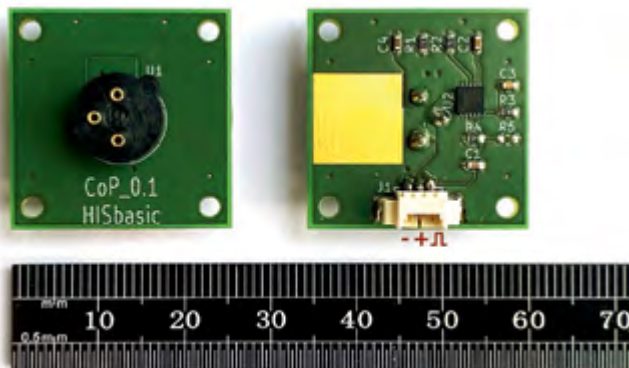

Fig. 2: Driving circuit board for a quick evaluation of EOC-IRE series IR emitters.

For a quick evaluation of EOC-IRE series IR emitters we offer a simple driving circuit board (Fig. 2). Please contact us for further technical details and ordering information. We will be pleased to support you on choosing the optimal drive mode for your system and application.