



Datasheet

AT-W1

Spanner Wrench for Fiber Adapter

Features

- **Spanner wrench for externally threaded fiber adapter series (PRA-FC, PRA-FSMA)**
- **Lightweight and durable material**
- **Allows adjustments in tight spaces**

Applications

- **Mounting of FEMTO fiber adapters to optical flanges with 1.035"-40 thread**

Scope of Delivery

AT-W1, datasheet, transport package

Specifications

General Data

Material	Al, anodized
Weight	12 g (0.03 lb)

Dimensions

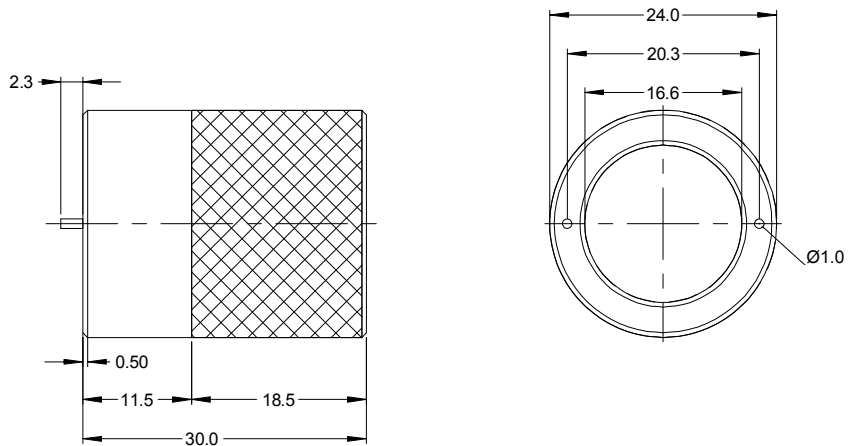

All measures in mm unless otherwise noted.