

Datasheet

HBPR-450M-10K-IN-FS(T)

High-Speed Balanced Photoreceiver



Features

- **Bandwidth DC to 450 MHz**
- **Common-Mode Rejection Ratio (CMRR) 35 dB typ.**
- **InGaAs-PIN detectors, 0.3 mm active diameter**
- **Spectral range 800 - 1700 nm**
- **Very low NEP, down to 6.5 pW/√Hz**
- **Transimpedance gain switchable 5×10^3 V/A, 10×10^3 V/A**
- **High dynamic input range up to 2×10 mW balanced optical power**
- **Fast monitor outputs with 10 MHz bandwidth and 1×10^3 V/A gain**
- **Switchable low pass filter for minimizing wideband noise**
- **Free-space input 1.035"-40 threaded, alternatively 25 mm diameter unthreaded**
- **UNC 8-32 and M4 tapped holes for mounting on standard posts with metric and imperial thread**

Applications

- **Spectroscopy**
- **Heterodyne detection**
- **Optical coherence tomography (OCT)**
- **Optical delay measurement**
- **Differential optical front-end for oscilloscopes, spectrum analyzers, A/D converters and RF lock-in amplifiers**

Block Diagram

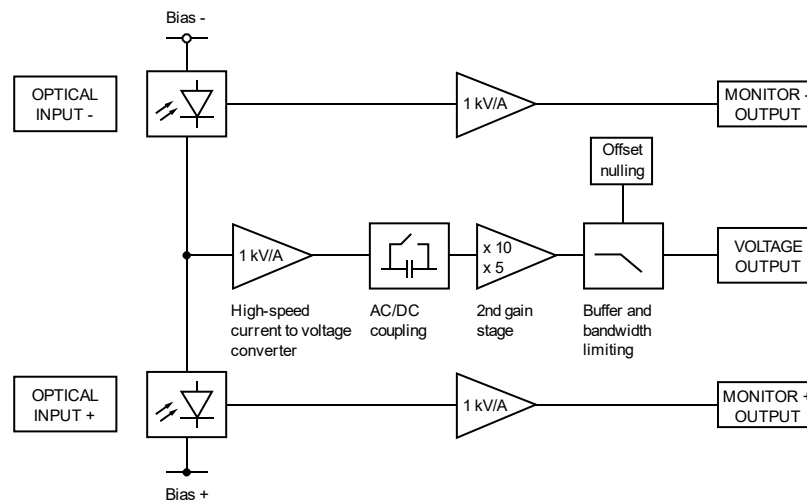

High-Speed Balanced Photoreceiver

Available Input Versions

HBPR-450M-10K-IN-FST



1.035"-40 threaded flange for free space applications, compatible with many optical standard accessories.

Picture shows two 1.035"-40 threaded flanges with internally threaded coupler rings mounted (outer diameter 30 mm)

HBPR-450M-10K-IN-FS



25 mm dia. unthreaded flange for free space applications compatible with many optical standard accessories.

Related Models

Various free space or fiber coupled HBPR models, with bandwidth up to 500 MHz, in the spectral range from 320 nm to 1700 nm are available.

Example: FC input



fix/permanent FC fiber connector for high coupling efficiency, excellent conversion gain accuracy and common mode rejection ratio (CMRR).

See further information and separate datasheets on www.femto.de

Available Accessory

PS-15



power supply,
input: 100 - 240 VAC,
output: ± 15 VDC, +400/-250 mA

Specifications

Gain

Test conditions

$V_s = \pm 15$ V, $T_A = 25$ °C, signal output terminated with 50 Ω , Monitor outputs terminated with 1 M Ω

Transimpedance gain

5 x 10³ V/A (2nd gain x5), 10 x 10³ V/A (2nd gain x10) switchable (@ 50 Ω load)

Gain accuracy

± 1 % electrical

Conversion gain

4.75 x 10³ V/W typ. (@ 2nd gain x5, 1550 nm)
9.50 x 10³ V/W typ. (@ 2nd gain x10, 1550 nm)

Common mode rejection ratio (CMRR)

50 dB typ. ($f \leq 100$ MHz)
35 dB typ. ($f \leq 450$ MHz)

Frequency Response

Lower cut-off frequency

DC / 10 Hz, switchable

Upper cut-off frequency

450 MHz, switchable to 20 MHz

High-Speed Balanced Photoreceiver

Specification (continued)

Time Response	Rise/fall time (10 % - 90 %)	0.95 ns (@ 2 nd gain x5); 1.02 ns (@ 2 nd gain x10) 17.50 ns (low pass filter 20 MHz)	
	Input	<p>Noise equivalent power (NEP) minimum 6.5 pW/√Hz (@ 1550 nm) 6.9 pW/√Hz (@ 1550 nm, 20 MHz) 20.0 pW/√Hz (@ 1550 nm, 200 MHz) 38.0 pW/√Hz (@ 1550 nm, 450 MHz)</p> <p>Maximum differential CW power for linear amplification 210 μW (@ 2nd gain x5, DC-coupled, 1550 nm) 105 μW (@ 2nd gain x10, DC-coupled, 1550 nm) 1.3 mW (@ AC-coupled, 1550 nm)</p> <p>Max. optical CW balanced power (common mode power) 10 mW (on each photodiode, @ 1550 nm)</p> <p>Monitor optical saturation power (limit for linear amplification) 10.5 mW (@ 1550 nm)</p>	
Detector	Detector	InGaAs-PIN photodiode	
	Active area	∅ 300 μm	
	Spectral range	800 - 1700 nm	
	Sensitivity	0.95 A/W typ. (@ 1550 nm)	
Signal Output	Output voltage range	±1.0 V (@ 50 Ω load) for linear operation and low harmonic distortion	
	Max. output voltage	±2.0 V (@ 50 Ω load)	
	Offset voltage compensation	±100 mV typ., adjustable by offset potentiometer	
	Output impedance	50 Ω (terminate with 50 Ω load)	
	Slew rate	2800 V/μs	
	Max. output current	70 mA	
	Output return loss S22	-30 dB @ < 100 MHz -20 dB @ < 800 MHz	
	Output noise	2.4 mV _{RMS} (16 mV _{PP}) (@ 2 nd gain x5) 4.6 mV _{RMS} (31 mV _{PP}) (@ 2 nd gain x10) 0.25 mV _{RMS} (1.7 mV _{PP}) typ. (@ 2 nd gain x5, BW: 20 MHz) 0.4 mV _{RMS} (2.7 mV _{PP}) typ. (@ 2 nd gain x10, BW: 20 MHz) (@ 50 Ω load, no signal on detectors, measurement bandwidth 2 GHz)	
	Monitor Outputs	Monitor output gain	1 x 10 ³ V/A (@ ≥ 100 kΩ load)
		Monitor output voltage range	0 ... +10 V (@ ≥ 100 kΩ load)
Monitor output impedance		50 Ω (terminate with ≥ 100 kΩ load)	
Monitor output max. output current		30 mA typ.	
Monitor output bandwidth		DC ... 10 MHz	
Monitor output noise		0.6 mV _{RMS} (4 mV _{PP}) (@ 100 kΩ load, no signal on detectors, measurement bandwidth 200 MHz)	
Input Flange	Material	1.4305 stainless steel, nickel-plated (FST flange) AlMg4.5Mn, nickel-plated (FS flange)	

High-Speed Balanced Photoreceiver

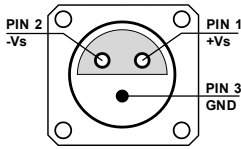
Specification (continued)			
Coupler Ring (FST version only)	Material	1.4305 stainless steel, glass bead blasted	
Power Supply	Supply voltage	$\pm 15\text{ V}$ ($\pm 14.5\text{ V}$... $\pm 16.5\text{ V}$)	
	Supply current	-90 / +120 mA (depends on operating conditions, recommended power supply capability min. $\pm 200\text{ mA}$)	
Case	Weight	350 g (0.77 lbs)	
	Material	AlMg3Mn, nickel-plated	
Temperature Range	Storage temperature	-40 ... +85 °C	
	Operating temperature	0 ... +60 °C	
Absolute Maximum Ratings	Max. CW power (averaged)	12 mW (on each photodiode)	
	Power supply voltage	$\pm 20\text{ V}$	
Connectors	Input	FS version	25 mm dia. unthreaded flange for free space applications
		FST version	1.035"-40 threaded flange for free space applications and for use with various types of optical standard accessories
	Output	SMA jack (female)	
	Power supply	Lemo® series 1S, 3-pin fixed socket (mating plug type: FFA.1S.303.CLAC52)	
			Pin 1: +15 V Pin 2: -15 V Pin 3: GND
Scope of Delivery	HBPR-450M-10K-IN, 2 x threaded coupler ring (FST version only), Lemo® 3-pin connector, 3 x adapter SMA (male) to BNC (female), datasheet		
Ordering Information	HBPR-450M-10K-IN-FS	25 mm dia. unthreaded flange for free space applications	
	HBPR-450M-10K-IN-FST	1.035"-40 threaded flange for free space applications and for use with various types of optical standard accessories	

High-Speed Balanced Photoreceiver

Spectral Responsivity

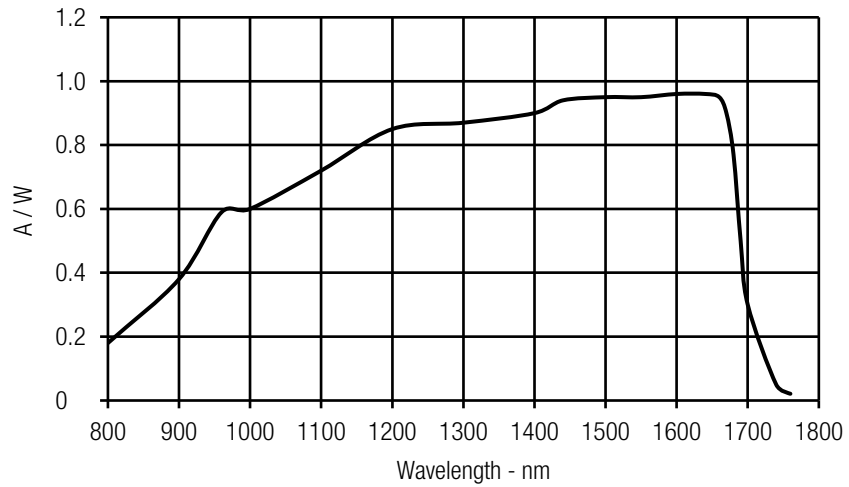

Detector Position

HBPR-450M-10K-IN-FST (1.035"-40 threaded free space input)

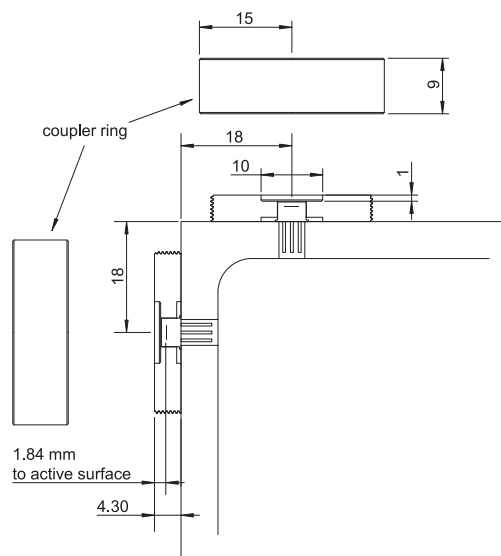

HBPR-450M-10K-IN-FS (25 mm dia. unthreaded free space input)

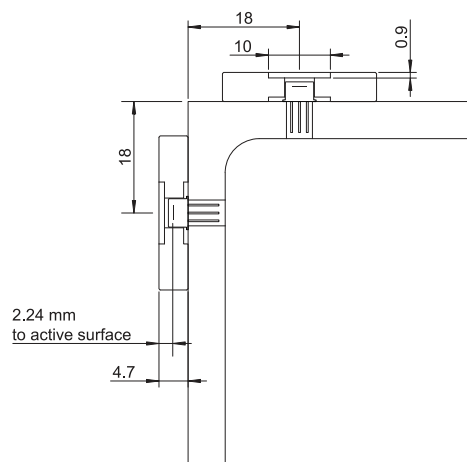

High-Speed Balanced Photoreceiver

Dimensions

Case dimensions for HBPR-450M-10K-IN (FS/FST model):

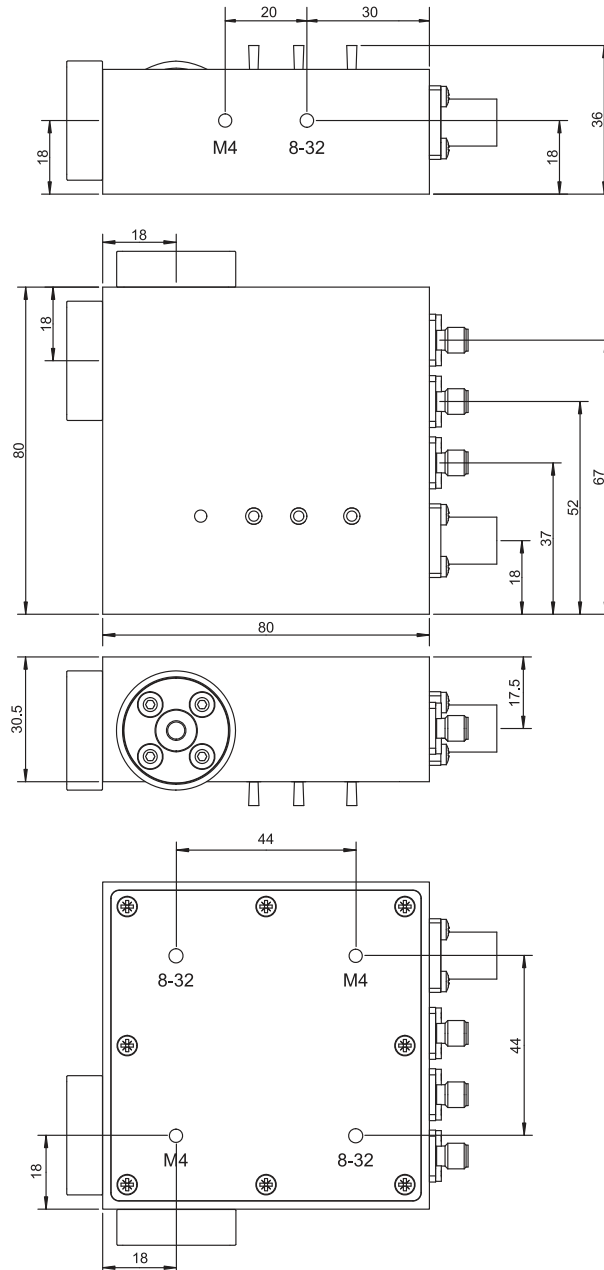

All measures in mm unless otherwise noted.

The bottom plate may be rotated to match the appropriate mounting thread to the optical axis by unscrewing the 8 screws.

Specifications are subject to change without notice. Information provided herein is believed to be accurate and reliable. However, no responsibility is assumed by FEMTO Messtechnik GmbH for its use, nor for any infringement of patents or other rights of third parties which may result from its use. No license is granted by implication or otherwise under any patent or patent rights of FEMTO Messtechnik GmbH. Product names mentioned may also be trademarks used here for identification purposes only.

© by FEMTO Messtechnik GmbH · Printed in Germany