



HQF Series Nanosecond Lamp Pumped Q-switched Laser



Applications

- Aesthetic medicine
- Differential absorption lidar
- Micromachining
- Laser-induced breakdown spectroscopy(LIBS)
- Laser-based ultrasound detection
- Tissue ablation
- Non-linear optics
- Laser ranging
- Particle image velocimetry(PIV)
- Laser shock processing(LSP)
- Laser-induced fluorescence (LIF)
- Raman spectroscopy

Key Features

- ◆ Various options of energy
- ◆ Compact design
- ◆ Excellent beam quality
- ◆ Cost effective



Beam Profile

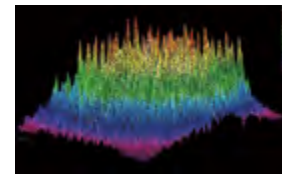

Beam intensity distribution

Technical Specifications

Part Number	HQF-1064/532-10-6-600/300-N	HQF-1064/532-10-6-800/400-N	HQF-1064/532-10-6-1200/600-N
Repetition rate (Hz)	1~10		
Pulse energy (mJ)			
1064nm	600	800	1200
532nm	300	400	600
Energy stability RMS			
1064nm	<2%		
532nm	<3%		
Power drift ¹			
1064nm	3%		
532nm	5%		
Other parameters			
Pulse width FWHM (ns)	6~8		
Beam full divergence (typ., mrad)	Horizontal @1/e ²	<5	
	Vertical @1/e ²	<5	
Pointing stability ² (μrad)	<20		
Time jitter ³ (RMS,ns)	<0.5		
Beam diameter (mm)	~8	~9	~9
Spatial profile	Top hat		
Polarization state	linear polarization		
Lamp lifetime (shot)	>6X10 ⁷		
Electrical Supply	220VAC±5% 50-60Hz		
Power consumption	<1.8kW(800mJ@10Hz)		
Environment requirements	temperature 5~35°C, humidity <80%		

1.Average energy variation is measured at room temperature with fluctuations less than 3°C within 8 hours.

2.Deviation from beam mean centroid.

3.With respect to external trigger.

Others: Lasers with wavelength at 355nm or 266nm can be customized upon request.

Order Information

Wavelength (nm)	Part Number	Repetition Rate (Hz)	Single Pulse Energy (mJ)	Pulse Width (ns)
1064/532	HQF-1064/532-10-6-600/300-N	1~10	600@1064nm 300@532nm	6.5
	HQF-1064/532-10-6-800/400-N	1~10	800@1064nm 400@532nm	6.5
	HQF-1064/532-10-6-1200/600-N	1~10	1200@1064nm 600@532nm	6.5

Part Numbering Schema

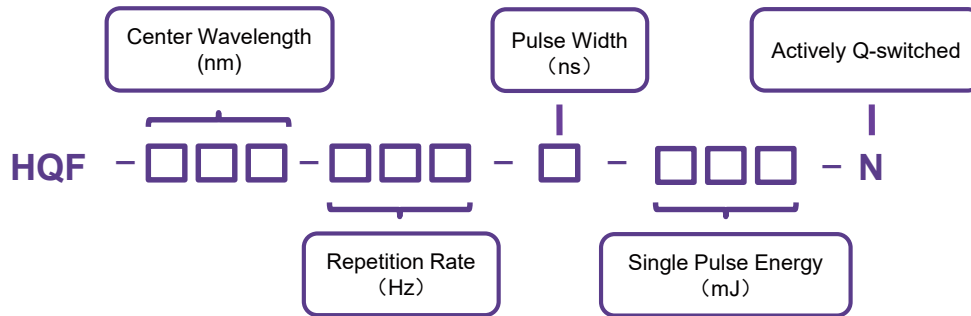

Mechanical Drawings (in mm)

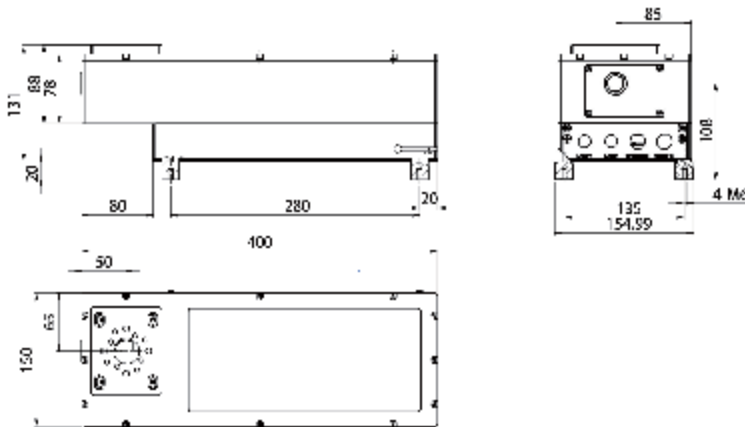

Single-lamp nanosecond lamp pumped Q-switched laser HQF-1064/532-10-6-600/300-N HQF-1064/532-10-6-800/400-N

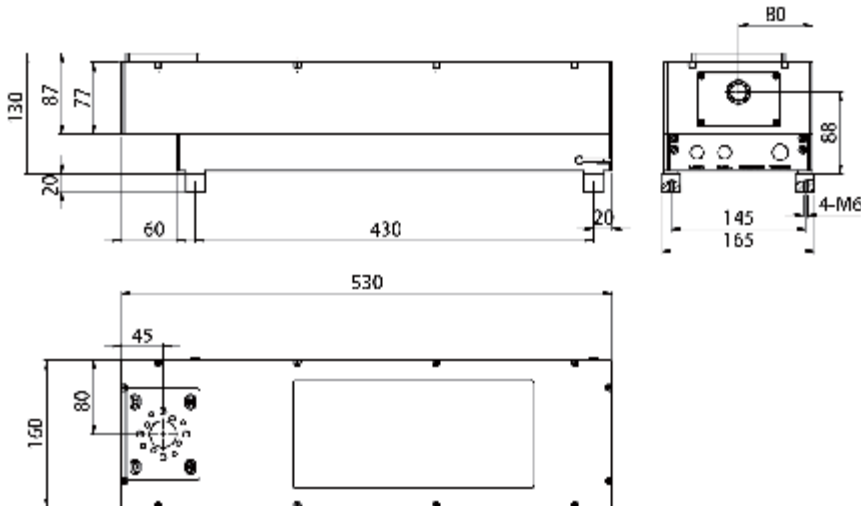

Double-lamp nanosecond lamp pumped Q-switched laser HQF-1064/532-10-6-1200/600-N

