



Electro Optical Components, Inc.

5464 Skylane Boulevard, Suite D, Santa Rosa, CA 95403

Toll Free: 855-EOC-6300

www.eoc-inc.com | info@eoc-inc.com



HQP Series High Peak Power Laser



Key Features

- ◆ Peak power up to 660kW
- ◆ Repetition rate up to 10kHz
- ◆ Total weight < 5kg
- ◆ Time jitter < 300ps available upon request
- ◆ Excellent beam quality
- ◆ Air cooled, low power consumption
- ◆ High reliability

Technical Specifications

Applications

- Laser-induced breakdown spectroscopy (LIBS)
- Laser ranging
- Tissue ablation
- Raman spectroscopy
- Laser-induced fluorescence (LIF)
- Laser-based ultrasound detection
- Scanning and imaging lidar
- Laser engraving
- Differential absorption lidar
- Precision drilling
- Mie-scattering lidar
- Laser cleaning / Additive manufacturing

Optical Parameters												
Wavelength (nm)	1064			532			1064			532		
Repetition rate (kHz)	2	5	10	2	5	10	2	5	10	2	5	10
Average power (W)	1	1.8	1.5	0.6	1	0.8	1	1.5	1.5	0.5	0.9	0.8
Pulse energy (µJ)	500	360	150	300	200	80	500	300	150	250	180	80
Pulse width (ps)	1500			1500			750			750		
Power stability (8h)	±3%											
Beam profile	TEM ₀₀											
Beam full divergence (typ., mrad)	Horizontal @1/e ²			2								
	Vertical @1/e ²			2								
Polarization ratio	≥ 100:1											
System Parameters												
Supply power voltage	100-240 VAC, 50/60 Hz											
Modulation input	TTL 0-5V, SMB input											
Trigger output	SMB Connector											
Control interface	RS232											
Power consumption (W)	≤ 350											
Power dimensions (W×H×L,mm)	124×70×265											
Laser head dimensions (W×H×L,mm)	140*67*230											
Operation temperature (°C)	15-35											
Storage temperature (°C)	0-50											

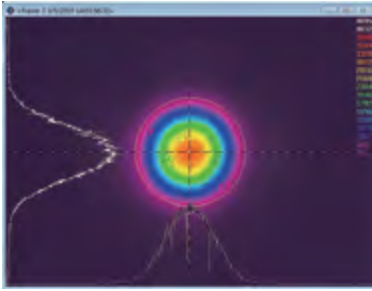

Beam Profile

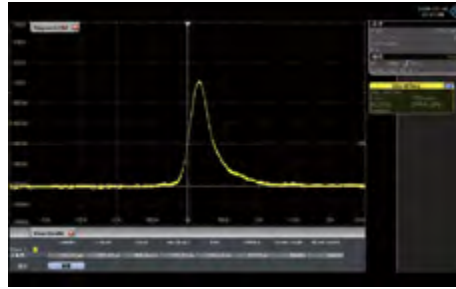

Typical Pulse Width

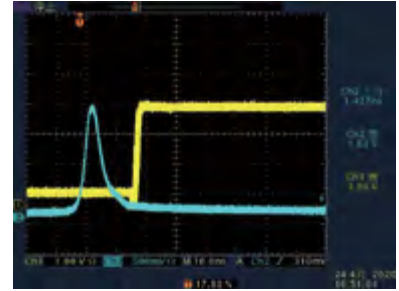

Photodiode output signal

Order Information

Wavelength (nm)	Part Number	Repetition rate (kHz)	Pulse energy (uJ)	Pulse width (ps)
1064	HQP-1064-2-500-1500	2	500	1500
	HQP-1064-5-360-1500	5	360	1500
	HQP-1064-10-150-1500	10	150	1500
	HQP-1064-2-500-750	2	500	750
	HQP-1064-5-300-750	5	300	750
	HQP-1064-10-150-750	10	150	750
532	HQP-532-2-300-1500	2	300	1500
	HQP-532-5-200-1500	5	200	1500
	HQP-532-10-80-1500	10	80	1500
	HQP-532-2-250-750	2	250	750
	HQP-532-5-180-750	5	180	750
	HQP-532-10-80-750	10	80	750

Mechanical Drawings (in mm)

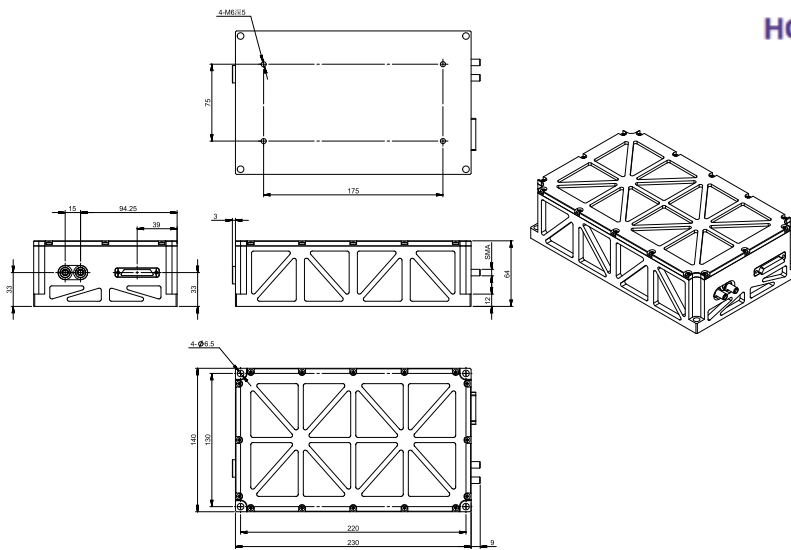

Laser Head

Part Numbering Schema

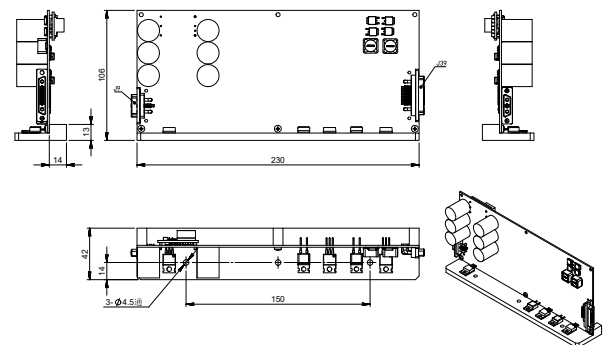
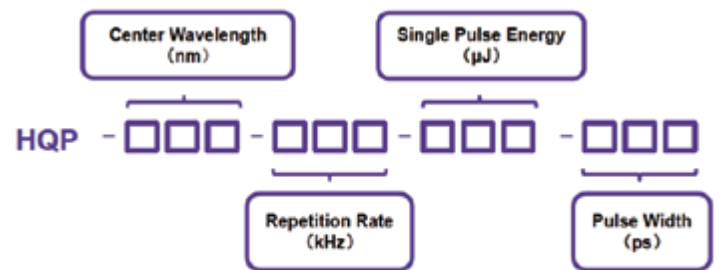

Drive Board

