



PCAS-2TE-9-0.1x0.1-TO8-wZnSeAR-70 detector

PCAS-2TE-9-0.1x0.1-TO8-wZnSeAR-70 – ENGINEERING SAMPLE

Type II superlattice, two-stage thermoelectrically cooled, photoconductive detector

PCAS-2TE-9-0.1x0.1-TO8-wZnSeAR-70 is a Type II superlattice two-stage thermoelectrically cooled IR photoconductor, with excellent parameters. Photoconductive detector should operate in optimum bias voltage and current readout mode. Performance at low frequencies is reduced due to 1/f noise. 3° wedged zinc selenide anti-reflection coated window (wZnSeAR) prevents unwanted interference effects. For detection of CW radiation, using of optical chopper system is recommended. This detector does not contain mercury or cadmium and is compliant with the RoHS Directive.

Spectral response ($T_a = 20^\circ\text{C}$)

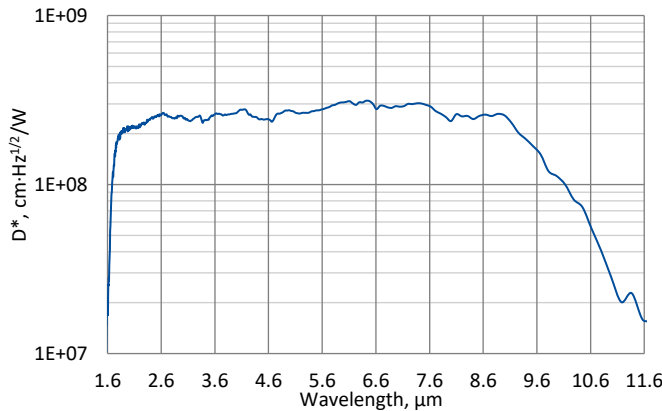

Exemplary spectral detectivity, the spectral response of delivered devices may differ.

Specification ($T_a = 20^\circ\text{C}$)

Parameter	Detector type
	PCAS-2TE-9-0.1x0.1-TO8-wZnSeAR-70
Active element material	epitaxial superlattice heterostructure
Cut-on wavelength $\lambda_{\text{cut-on}}$ (10%), μm	1.6 ± 0.2
Peak wavelength λ_{peak} , μm	6.2 ± 0.3
Cut-off wavelength $\lambda_{\text{cut-off}}$ (10%), μm	11.0 ± 0.3
Detectivity $D^*(\lambda_{\text{peak}}, 20 \text{ kHz})$, $\text{cm}\cdot\text{Hz}^{1/2}/\text{W}$	$\sim 2.8 \times 10^8$
Current responsivity $R_i(\lambda_{\text{peak}})$, A/W	~ 2.8
Time constant τ , ns	~ 12
Resistance R , Ω	~ 95
Bias voltage V_b , V	typ. 0.5
1/f noise corner frequency f_c , Hz	typ. 20k
Active element temperature T_{det} , K	~ 230
Active area A , mm \times mm	0.1 \times 0.1
Package	TO8
Acceptance angle Φ	$\sim 70^\circ$
Window	wZnSeAR

Features

- Wide spectral range from 1.6 to 11.0 μm
- High responsivity
- Excellent linearity
- Environmentally friendly

Two-stage thermoelectric cooler parameters

Parameter	Value
T_{det} , K	~ 230
V_{max} , V	1.3
I_{max} , A	1.2
Q_{max} , W	0.36

Thermistor characteristics

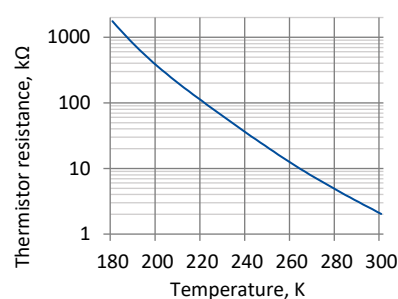

Linearity (typ., $T_{\text{BB}} = 1273 \text{ K}$)

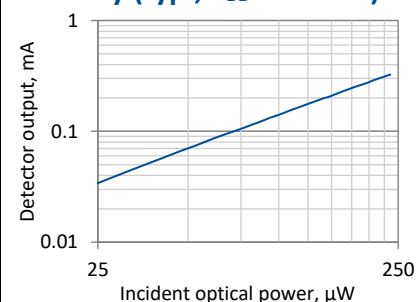

T_{BB} – black body temperature

Mechanical layout, mm

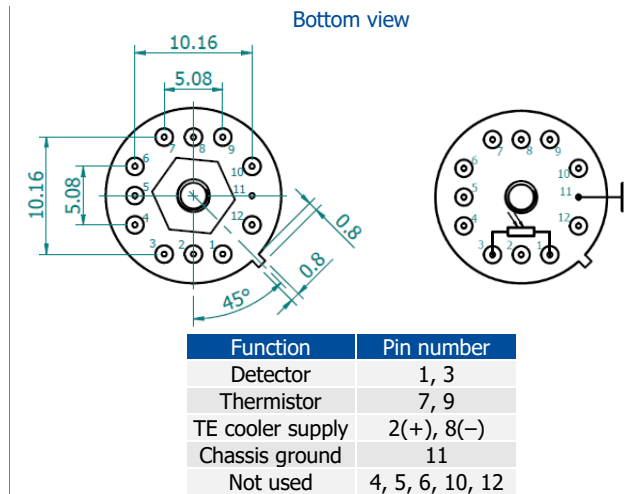
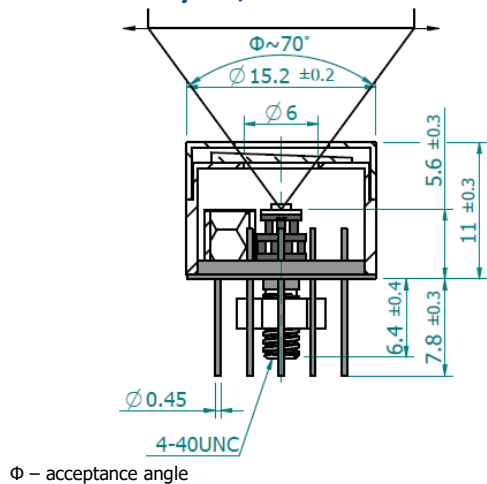

Dedicated preamplifiers



„all-in-one“ AIP



programmable PIP



standard MIP



small SIP-TO8

Precautions for use and storage

- Heatsink with thermal resistance of ~2 K/W is necessary to dissipate heat generated by 2TE cooler.
- Operation in 10% to 80% humidity and -20°C to 30°C ambient temperature.
- Beam power limitations:
 - irradiance with CW or single pulse longer than 1 μs irradiance on the apparent optical active area must not exceed 100 W/cm²,
 - irradiance of the pulse shorter than 1 μs must not exceed 1 MW/cm².
- Storage in dark place with 10% to 90% humidity and -20°C to 50°C ambient temperature.