



Electro Optical Components, Inc.

5464 Skylane Boulevard, Suite D, Santa Rosa, CA 95403

Toll Free: 855-EOC-6300

www.eoc-inc.com | info@eoc-inc.com



TECHNICAL DATA SHEET V/P200



Intelligent Black edition gas pumps

2. General information
3. General flow performance
4. Standard models
5. Electronic interface
8. Serial interface
10. Performance charts
11. Drawings



BLACK EDITION MICRO PUMPS FROM XAVITECH

Xavitech's Black edition is our pump model with the most functionality and flexibility. Our goal is for you to be able to use this micro pump in your new system or as a drop-in replacement in your existing system easily and conveniently.

GUARANTEED LIFETIME

- Small footprint
- Easy to install with vibration absorbing pump mountings
- Customized calibrations
- Flex cable or flying leads
- Silent mode
- Can operate on battery
- Choose the operating voltage between 3.3VDC – 24VDC

SELECT THE LIFETIME

At Xavitech you can choose between 3 different lifetimes:

Choose between:

- | | |
|---------------|-------------------|
| 10 000 hours | (1-year warranty) |
| 20 000 hours | (2-year warranty) |
| +35 000 hours | (3-year warranty) |

CUSTOM CALIBRATION

The Intelligent Black edition pumps have built-in micro-controllers which makes it possible to create customized firmware for various purposes.

Examples of customized firmware:

- Set the flowrate to a specific value
- Silent mode

Contact us if you are wondering how the Black edition pump can best serve your system.

ANALOG OR INTELLIGENT?

The Black edition pumps are divided into two categories; The Analog edition and the Intelligent edition. The analog edition comes with a 3-cable connection and allows for analog control and can be used with our AFC for easy experimenting. See separate datasheet for more information.

The Intelligent edition has serial control and can be programmed by you. Use one of our adaptors (App, computer adaptor or FCU) for easy experimenting or use Arduino for example.

All Black edition pumps can be custom calibrated, to a set flow for example, by us at the factory.

P/V200 BLACK INTELLIGENT PUMP

General flow performance

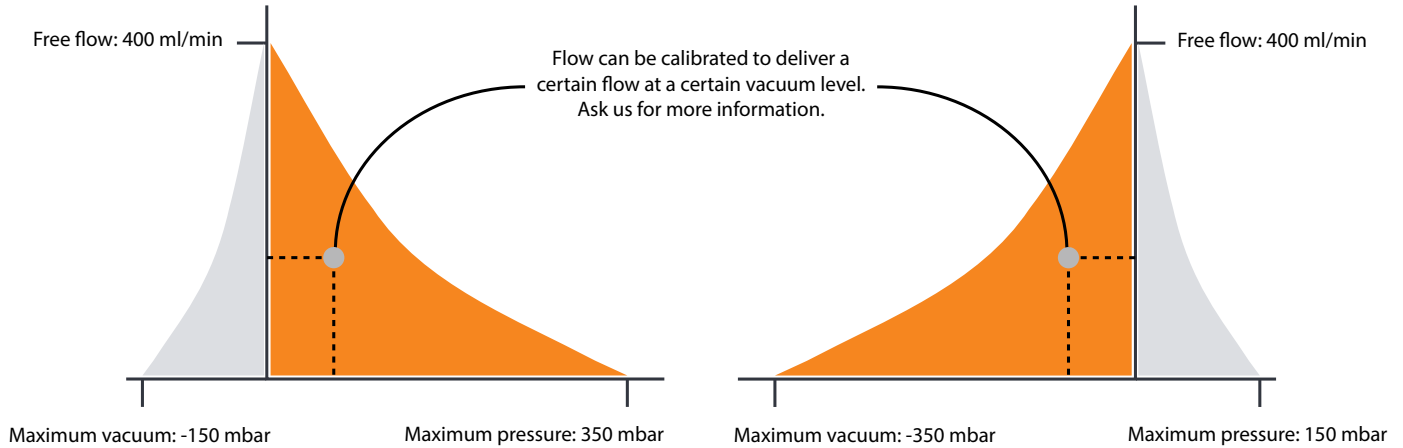

IMPORTANT NOTES

- Pump Flow: Flow is one-directional, it cannot be reversed
- Filters: To ensure lifetime, air filters should be used to prevent contaminations like dust to enter the pump
- Capacitor: Missing VCC capacitor can damage the pump on 24-volt variants. See the electronic interface section for capacitor suggestions
- Connections: Incorrect lead connection can damage the pump

P/V200 BLACK INTELLIGENT PUMP

Standard models

STANDARD MODELS (PART NUMBER)

Xavitech provides several pre-calibrated standard models. For these models, the voltage and the maximum flow is calibrated to standard values. When buying a standard pump, you still have a few choices you can make. Choose voltage, connection and lifetime. And if you're pumping aggressive gases you can choose Viton or Kalrez membranes. The chart below lists the standard pumps models that Xavitech can offer. But custom calibration is also an option, please contact Xavitech for more information.

PART NUMBER	VOLTAGE (V DC)	FREE FLOW (ml/min)	MAXIMUM PRESSURE/ MAXIMUM VACUUM (mbar)	CONNECTION INTERFACE	ANALOG FLOW CONTROL	SERIAL INTERFACE (RS-232)	LIFE TIME (Hours)
P200-BF5V	5	400	300	Flex cable	✓	✓	10 000 - +35 000
P200-BF12V	12	400	350	Flex cable	✓	✓	10 000 - +35 000
P200-BF24V	24	400	350	Flex cable	✓	✓	10 000 - +35 000
P200-B5C5V	5	400	300	5 Wires	✓	✓	10 000 - +35 000
P200-B5C12V	12	400	350	5 Wires	✓	✓	10 000 - +35 000
P200-B5C24V	24	400	350	5 Wires	✓	✓	10 000 - +35 000
V200-BF5V	5	400	-300	Flex cable	✓	✓	10 000 - +35 000
V200-BF12V	12	400	-350	Flex cable	✓	✓	10 000 - +35 000
V200-BF24V	24	400	-350	Flex cable	✓	✓	10 000 - +35 000
V200-B5C5V	5	400	-300	5 Wires	✓	✓	10 000 - +35 000
V200-B5C12V	12	400	-350	5 Wires	✓	✓	10 000 - +35 000
V200-B5C24V	24	400	-350	5 Wires	✓	✓	10 000 - +35 000

CONTROL

Read more about how to control the pump flow with either analog signal or with serial interface and how to choose your custom calibration point in the respective sections down below.

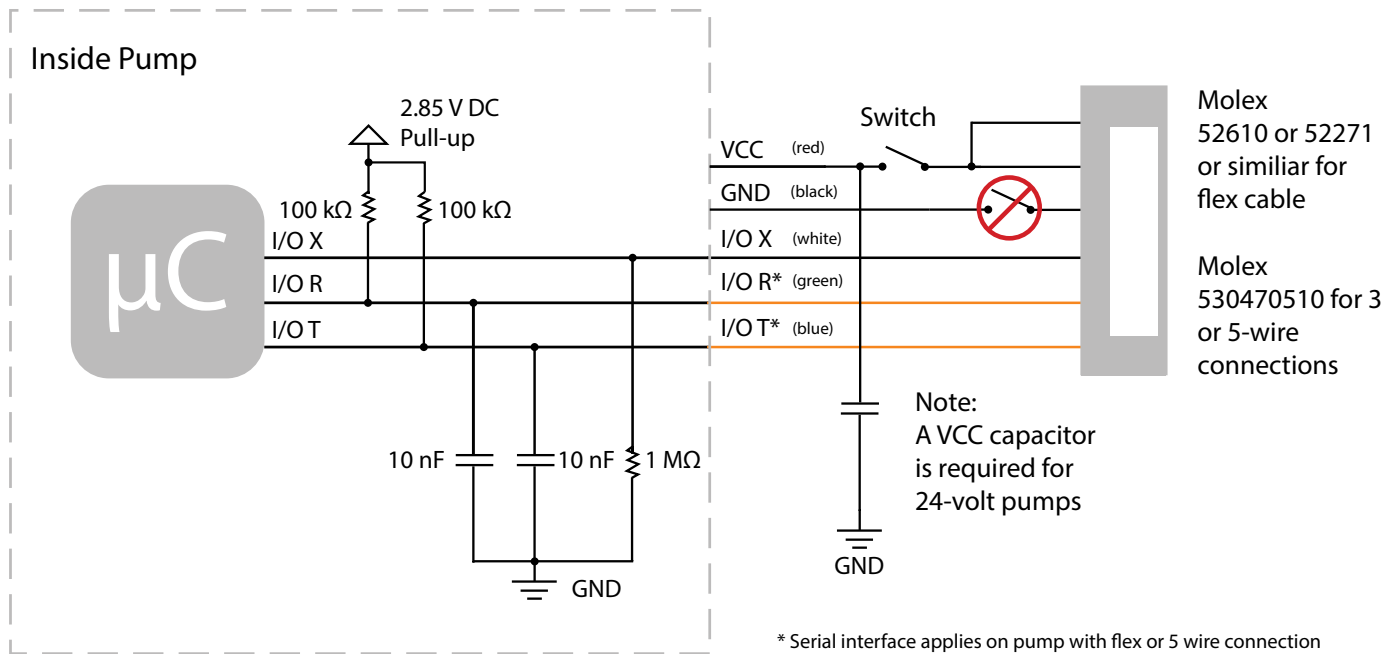

Figure 2: Electronic interface

INTERFACE DESCRIPTION

VCC (SUPPLY VOLTAGE)

Each pump is calibrated to run at an input voltage in the range of 3.2 to 24 V DC. The supply voltage can be customized for each customer's need.

Maximum input voltage: Calibrated voltage + 0.5 V DC. The pump can be damaged otherwise.

Minimum input voltage: 3.2 V DC. However, the pump performance is reduced if the voltage is set lower than calibrated value. Xavitech recommends to always run the pump at the calibrated voltage.

Figure 3 shows in terms of current consumption a typical pump stroke cycle. Since the motor of Xavitech pumps is based on an electromagnet, a negative current will occur when the electromagnet is turned off. It is because of this current a capacitor is needed between VCC and GND.

If your system cannot handle this spike generated by the electromagnet, a Schottky diode (flyback diode) can be used instead of the capacitor.

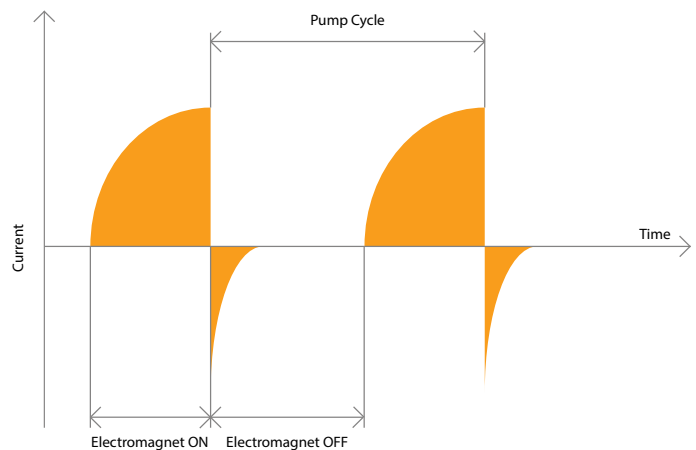

Figure 3: Typical pump cycle

I/O X

This is a general I/O connected to an A/D converter of the microcontroller inside the pump.

The default functionality is frequency control:

- 0 – 0.05 V DC: Maximum frequency of the pump
- 0.06 – 2.75 V DC: Frequency control of the pump
- 2.75 – 2.85 V DC: Pump stops
- Max input voltage: 3.3 V DC (the pump can be damaged if exceeded)

Note that the frequency adjustment can only lower the frequency from the factory default frequency. Normally a pump is calibrated to have its maximum frequency (maximum flow) set as default at factory.

The use of I/O X can be customized for each customer's need. I/O X can be an analog- or digital input or output. Please contact an Xavitech representative for more information.

I/O R

This connector is connected to the Receive pin of the internal microcontroller UART. Note that a pull-up voltage of 2.85 V DC is applied.

The serial interface uses RS-232 with TTL levels of 2.85 V DC. The maximum rating of this connector is 3.3 V DC. Read more about this in the documentation for the pumps serial interface.

I/O T

This connector is connected to the Transmit pin of the internal microcontroller UART. Note that a pull-up voltage of 2.85 V DC is applied.

The serial interface uses RS-232 with TTL levels of 2.85 V DC. The maximum rating of this connector is 3.3 V DC. Read more about this in the documentation for the pump serial interface.

SWITCH THE PUMP ON AND OFF

The Intelligent Xavitech pump can be turned on and off in three different ways:

- 1) Via the I/O X connector: Apply a voltage of at least 2.75 V DC (max 3.3 V DC) and the pump will stop. The pump will start within a few milliseconds (depending on what frequency the pump is calibrated in default) when a voltage lower than 2.75 V DC is applied. However, note that the internal microcontroller will still run so the pump will consume <10 mA.
- 2) Via the serial interface: Use the specific STOP command and the pump will stop. Then use the START command to start the pump. Note that the internal microcontroller will still run while stopped in this way, so the pump will consume <10 mA.
- 3) Switch power on and off: Note that the power has to be switched off on the supply connector (see Figure 1) and that the capacitor has to be placed between the pump and the switch. This is because of the current that the electro-magnet generates. The pump will be damaged if the switch is placed on the ground connector. The pump will in this case not consume any power, but the microcontroller will perform the start-up procedure which takes up to 3 s (depending on default pump frequency) when the power is turned on. During this time, the pump adjusts the stroke length to reach its calibrated length. The regulation adjusts the stroke length for every pump stroke thus it depends on the pump frequency.

CAPACITOR SPECIFICATIONS

Xavitech recommends using a capacitor parallel to the power supply (see Figure 2) to reduce the power spikes generated by the electromagnetic motor. For 24-volt pumps, a VCC capacitor is required to not damage the pump. See the recommended capacitors sizes below.

Pump	Recommended capacitor
V200-5V	47 μ F, 10 V
V200-12V	100 μ F, 16 V
V200-24V	470 μ F, 35 V
P200-5V	47 μ F, 10 V
P200-12V	100 μ F, 16 V
P200-24V	470 μ F, 35 V

COMMUNICATION SETTINGS

Asynchronous communication, 9 600 baud, 8 bits, 1 start bit, 1 stop bit, no parity
Voltage level: 2.85 V DC (Max 3.3 V DC)

SERIAL PROTOCOL

Communication package:

<SNHi> <SNMi> <SNLo> <NetID> <ADRHi> <ADRLo> <R/W-AMOUNT> <DATAI> <DATAx> <CHKSM>

Pump serial number: <SNHi> <SNMi> <SNLo>

Pump serial number, if you wish to address a pump in a system with more than one pump these values can be set from 1-16777215. However, the general call is 0, which will be the default.

Pump netId: <NetID>

Can also be used to address single pumps with a value from 1-255. 0 will be used as a general call and that is also the default value.

Memory address (EEPROM and RAM): <ADRHi> <ADRLo>

ADRHi uppermost 2 bits is setting for which memory type to access. Lower 6 bits of ADRHi and ADRLo byte forms the memory address.

ADRHi = 00XXXXXX = RAM

ADRHi = 01XXXXXX = EEPROM

Memory address pointer = (ADRHi AND 00111111) * 256 + ADRLo

Amount of data: <R/W-AMOUNT>

Number of bytes to read or write to either the RAM or the EEPROM.

<R/W-AMOUNT> = 00XXXXXX = Read from memory

<R/W-AMOUNT> = 10XXXXXX = Write to memory

Number of bytes to read/write is the lower 6 bits + 1. So if you want to read 1byte the lower 6 bits should be 0 (0+1=1), if they are set to 63 (bin XX111111) you will read 64 bytes (63+1=64).

Data bytes: <DATAx>

The number of data bytes defined in <R/W-AMOUNT>. Note: data bytes should be provided for both read and write commands. Add zeroes as data bytes when doing a read command.

Package checksum: <CHKSUM>

Add every byte in the package (without carry/overflow) to calculate checksum.

Response from the pump:

If a read command is sent to the pump a 3 byte response will be sent. The pump will at least send an integer value and a checksum. The number of bytes is defined by the chosen amount of data.

<DATAI> <DATAx> <CHKSUM>

If a write command is executed the pump will answer <165> if the command was successful executed and <90> if it failed.

Serial Commands

Flow control (pump frequency adjustment)

The pump frequency, and thus the flow, can be changed independently of the applied voltage. This is an important feature that enables flow control independently of supply voltage and thus a lower flow can be achieved without reducing maximum vacuum/pressure. This also reduces current consumption and the need for flow restrictors. It is both cost-effective and power-efficient.

Command address: 0x017E (hex), 382 (dec)

Command package: <0> <0> <0> <0> <1> <126> <129> <Lo Byte> <Hi Byte> <CHKSM>

The frequency is defined as a 16-bit number and is actually a delay time between each pump stroke.

Highest frequency/highest flow: 16-bit number = 0 (Default calibrated flow)

Lowest frequency/lowest flow: 16-bit number = 65 535

Example: <0> <0> <0> <0> <1> <126> <129> <232> <3> <235>

16-bit value = 0x03E8 (hex), 1000 (dec)

The response if command was successfully written: <165>

Read firmware (special command)

Command package: <0> <0> <0> <0> <192> <0> <1> <0> <0> <193>

Get the firmware version of the pump. 1 byte with the checksum of entire flash will be sent from the pump.

Stop pump

Command address: 0x007A (hex), 122 (dec)

Command packages:

First: <0> <0> <0> <0> <0> <122> <129> <0> <0> <251>

Wait for: <165>

Then: <0> <0> <0> <0> <0> <37> <129> <0> <0> <166>

Wait for: <165>

Start pump

Command address: 0x007A (hex), 122 (dec)

Command package: <0> <0> <0> <0> <0> <122> <129> <220> <0> <215>

The pump starts without the initial start-up process.

Reset pump (special command)

Command package: <0> <0> <0> <0> <128> <0> <1> <0> <0> <129>

The pump starts with the initial start-up process.

P/V200 BLACK INTELLIGENT PUMP

Performance charts

PERFORMANCE CHARTS

The charts show typical performance and are provided as a reference. Exact performance will differ between pump individuals.

Flow Vs. Pressure (P200 @ 5 V DC)

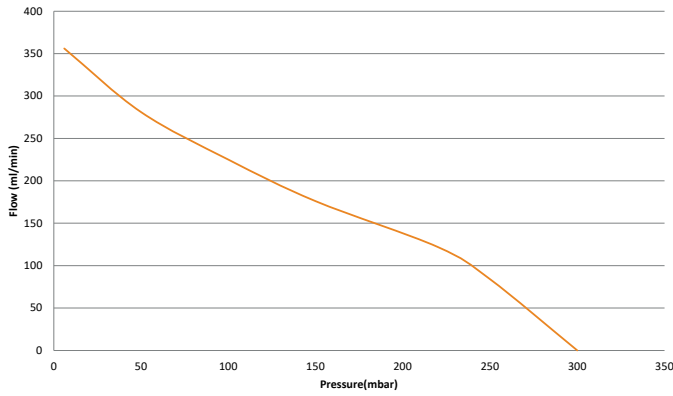

Flow Vs. Pressure (P200 @ 12 V DC)

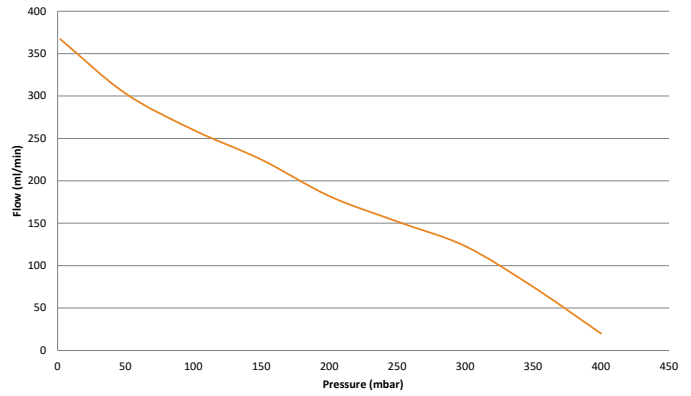

Flow Vs. Vacuum (V200 @ 12 V DC)

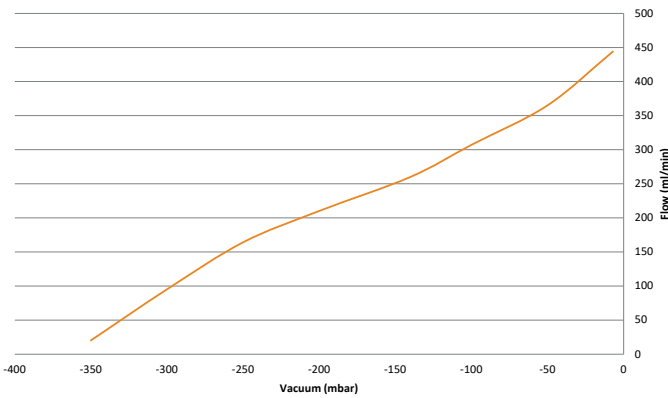

Flow Vs. Vacuum (V200 @ 5V DC)

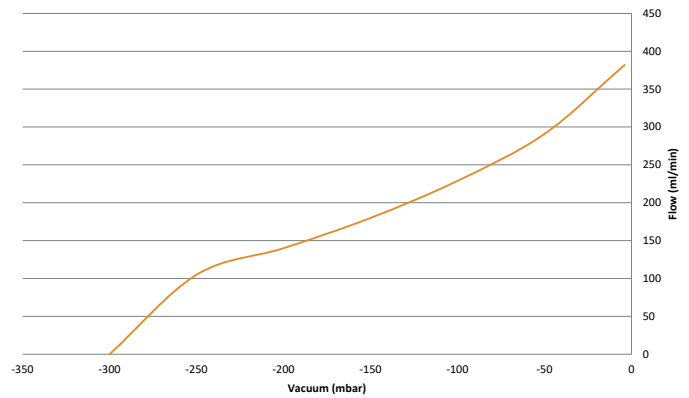

BLACK EDITION P200 AND V200 WITH FLEX CABLE

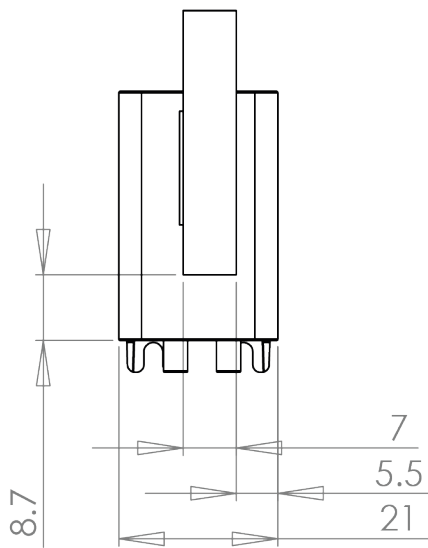
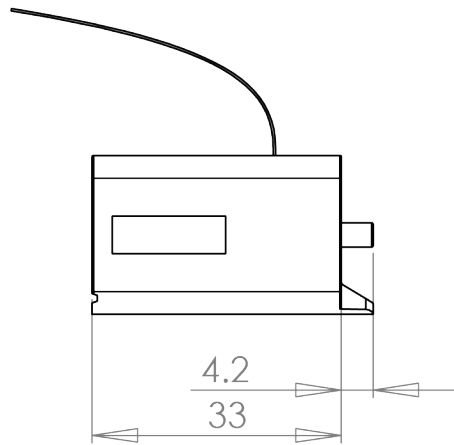
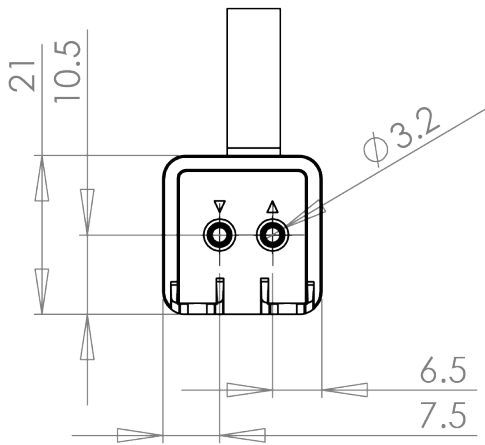

PUMP MODEL	V200 AND P200 BLACK EDITION
Connection	Flex connection
Drawing Scale	1:1
Dimension Tolerance	± 0.2 mm
Pump Weight	40 ± 2 g
Recommended Connectors	Flex 52610 or 52271
Recommended Tube Inner Diameter	1.6 - 2.8 mm (Material dependent)

P/V200 BLACK INTELLIGENT PUMP

BLACK EDITION P200 AND V200 WITH 3 OR 5 WIRE CONNECTION

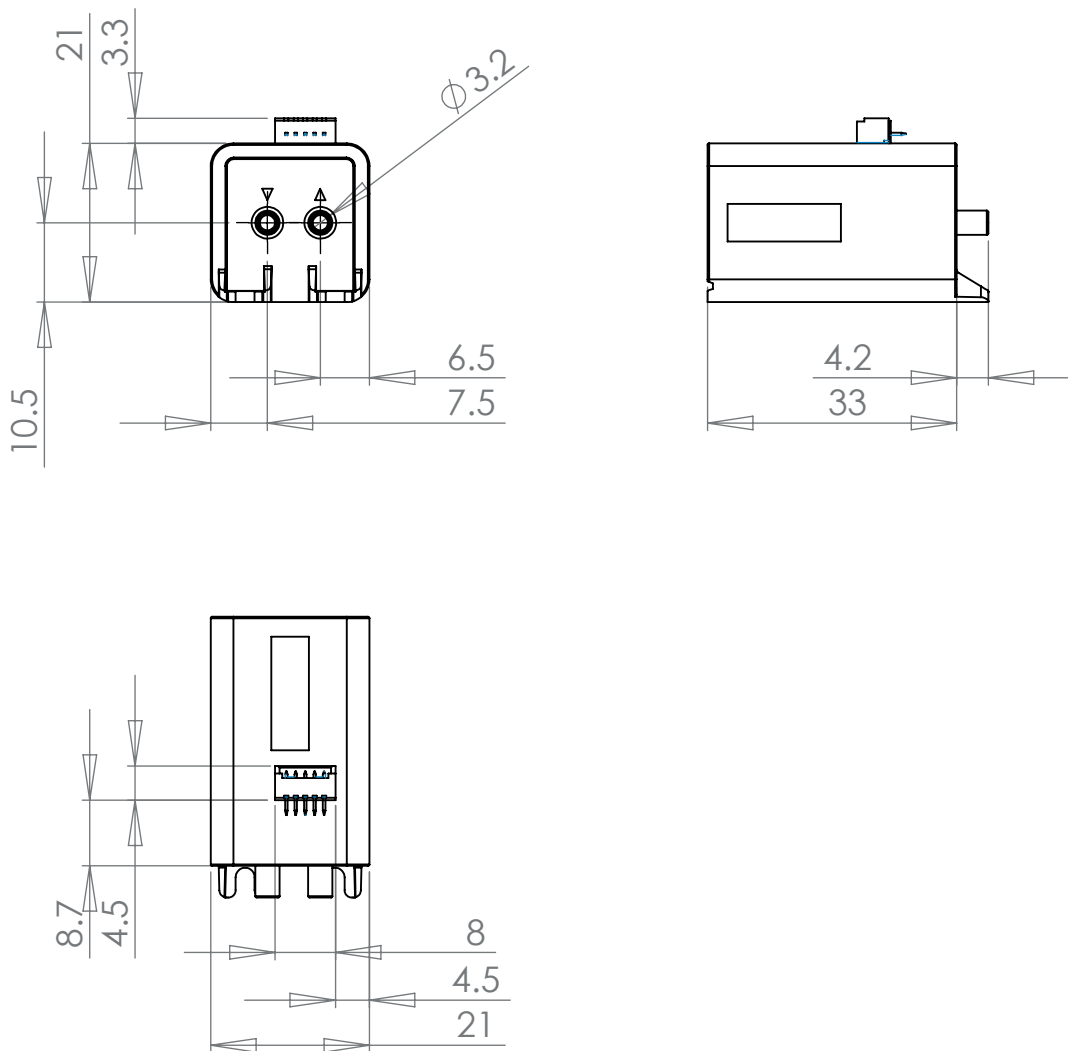

PUMP MODEL	V200 AND P200 BLACK EDITION
Connection	3 or 5 wires
Drawing Scale	1:1
Dimension Tolerance	± 0.2 mm
Pump Weight	40 \pm 2 g
Recommended Connectors	MOLEX 530470510 (Picoblade)
Recommended Tube Inner Diameter	1.6 - 2.8 mm (Material dependent)

This information is accurate and reliable. However, specifications mentioned in this publication are subject to change without notice. This publication supersedes and replaces all information previously supplied. Xavitech products are not authorized for use as critical components in life support devices or systems without express written approval of Xavitech.

© 2021 Xavitech - All Rights Reserved

XAVITECH MICROPUMPS AB. INDUSTRIGATAN 17. 871 53. HÄRNÖSAND. SWEDEN. TELEPHONE +46 (0) 611 55 61 00. E-MAIL: XAVITECH@XAVITECH.COM